

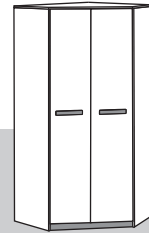

www.MLMEBLE.pl



GB assembly instructions / D montageanleitung / CZ montážní návod / SK montážny návod / RU инструкции по монтажу / LT surinkimo instrukcija



INSTRUKCJA MONTAŻU

BEST 01

199 92 92

akcesoria / accessories / zubehör / příslušenství / prislušenstvo / аксессуары / furnitūra :

| | | | | | | | | | | |
|---------------------|-----------------------|-----------------------|------------------------|-------------------|-------------------|---|-----------------|---------------------|--|---|
| x 22 KK 8/32 | x 17 KT 6,3/50 | x 8 ZA N | x 100 GZ 1,4/25 | x 8 SG 8/8 | x 17 MD | x 11 ZAM | x 4 UB 0 | x 24 PA Ø5 | x 30 WT 3,5x16 | x 4 WT 4x30 |
| x 6 ZA 45° | x 6 PK H-4 | x 12 WE 6,3x30 | x 2 PO Ø5 E | x 24 BDP | x 6 DPP 03 | x 2 drażek / stick / stock / hůl / palica / трость / strypas | x 1 LT | x 2 UT 1.839 | x 1 klej / glue / kleber / lepidlo / lepidlo / клей / kljaj | x 1 kluczyk / key / schlüssel / klíč / ключ / raktas |

do montażu potrzebne są:

are needed for assembly:
sind erforderlich für die montage:
jsou potřebné pro montáž:
sú potrebné pre montáž:
сú потрібні для сборки:
Surinkimui reikės:

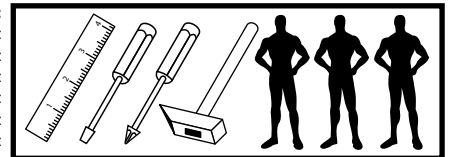

UWAGA ! - W pierwszej kolejności wbijamy akcesoria „KK” i „MD” w blaty oraz boki i montujemy prowadnice.

WARNING! - In the first place should be driven accessories "KK" and "MD" in the tops and sides and guides.

WARNUNG! - In erster Linie sollte Accessoires "KK" und "MD" in den Wipfeln und an den Seiten und Guides gefahren werden.

POZOR! - V první řadě by měl být tažen příslušenství "KK" a "MD" v korunách a po stranách a průvodců.

POZOR! - V prvom rade by mal byť ťahaný príslušenstvo "KK" a "MD" v korunách a po stranách a sprievodcov.

ВНИМАНИЕ! - В первую очередь следует руководствоваться аксессуарами "KK" и "MD", на вершинах и по бокам и руководства.

DĚMESIO! - Pirmiausiai furnitūrą KK ir MD įkalame į stalviršį ir šonus ir prisukame bėgelius.

UWAGA ! - w pierwszej kolejności wbijamy akcesoria „KK” i „MD” w blaty oraz boki.

WARNING! - The first accessory sticks "KK" and "MD" in the tops and sides.

WARNUNG! - Die erste Accessoire-Sticks "KK" und "MD" in den Spitzen und an den Seiten.

POZOR! - První příslušenství holí "KK" a "MD" v korunách a boky.

POZOR! - Prvé príslušenstvo palíc "KK" a "MD" v korunách a boky.

ВНИМАНИЕ! - Первый аксессуар палочки "KK" и "MD" по вершинам и по бокам.

DĚMESIO! - Pirmiausiai furnitūrą KK ir MD įkalame į stalviršį ir šonus.

| Nr/No | Szt/Qty |
|-------|---------|
| 1 | 1 |
| 2 | 2 |
| 3 | 1 |
| 4 | 2 |
| 5 | 1 |
| 6 | 1 |
| 7 | 1 |
| 8 | 1 |
| 9 | 1 |
| 10 | 1 |
| 11 | 3 |
| 12 | 1 |
| 13 | 3 |
| 14 | 1 |
| 15 | 2 |
| 16 | 2 |
| 17 | 2 |
| 18 | 1 |

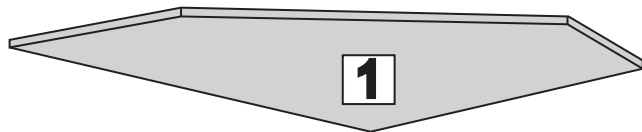

2

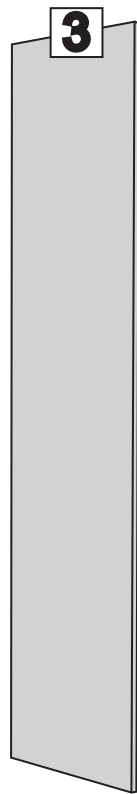

4

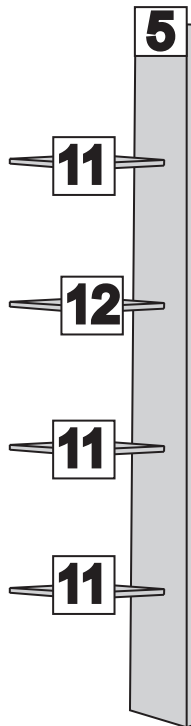

5

11

12

11

11

10

6

7

13

14

13

13

4



8

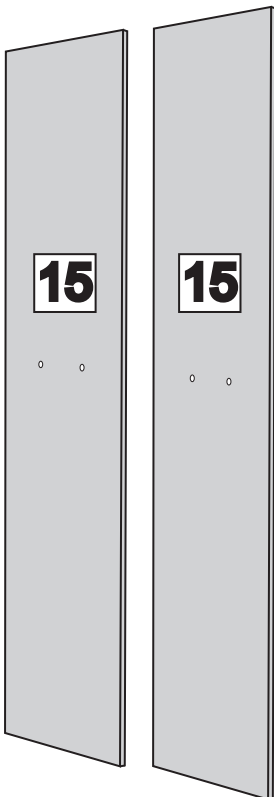

15

15

2

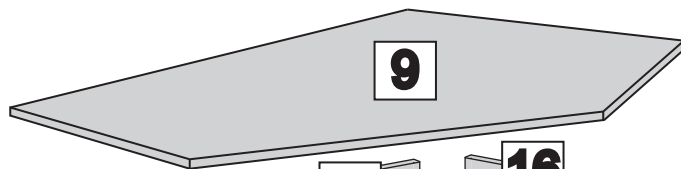

9



16



16



17



17



18

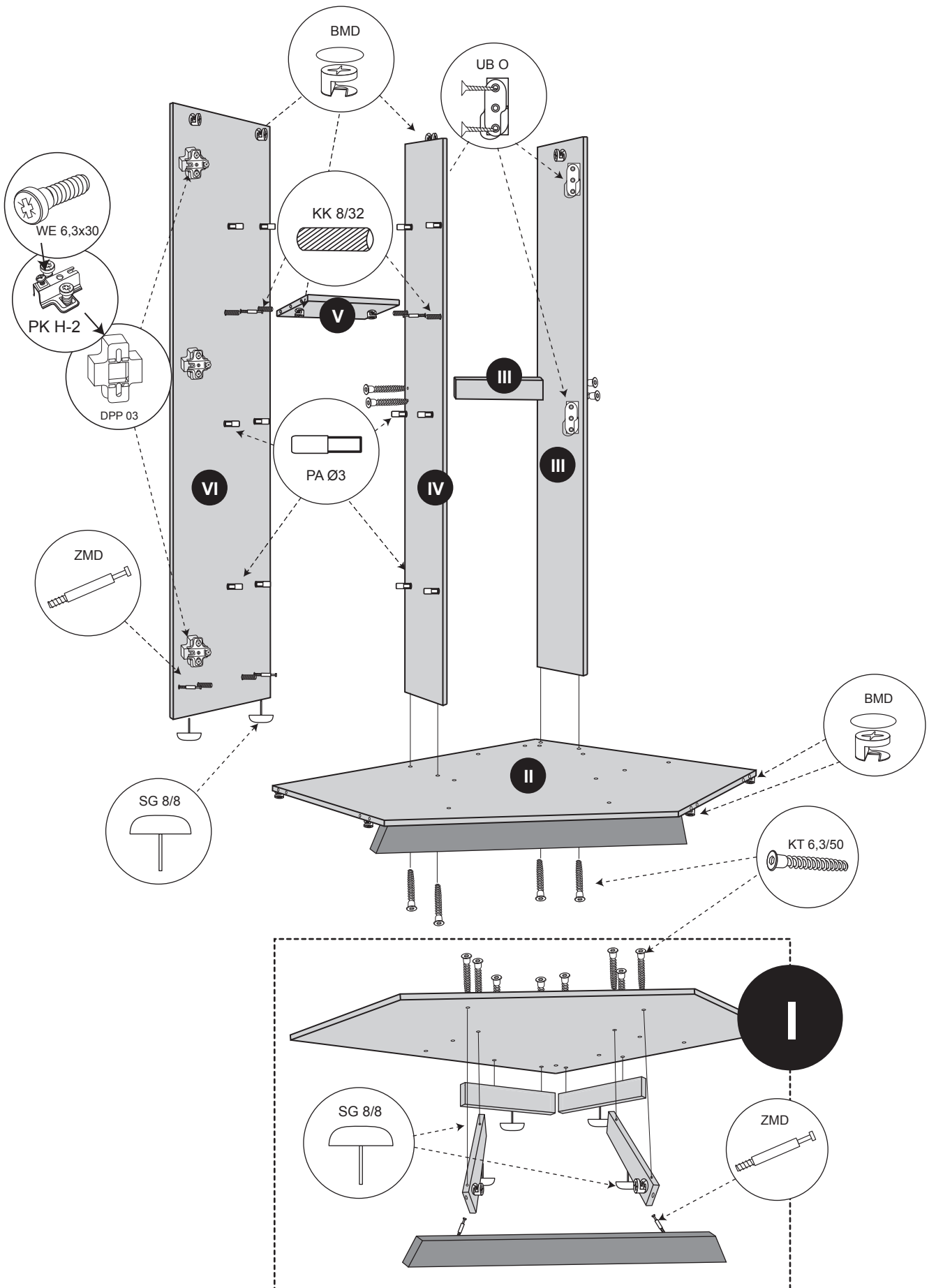

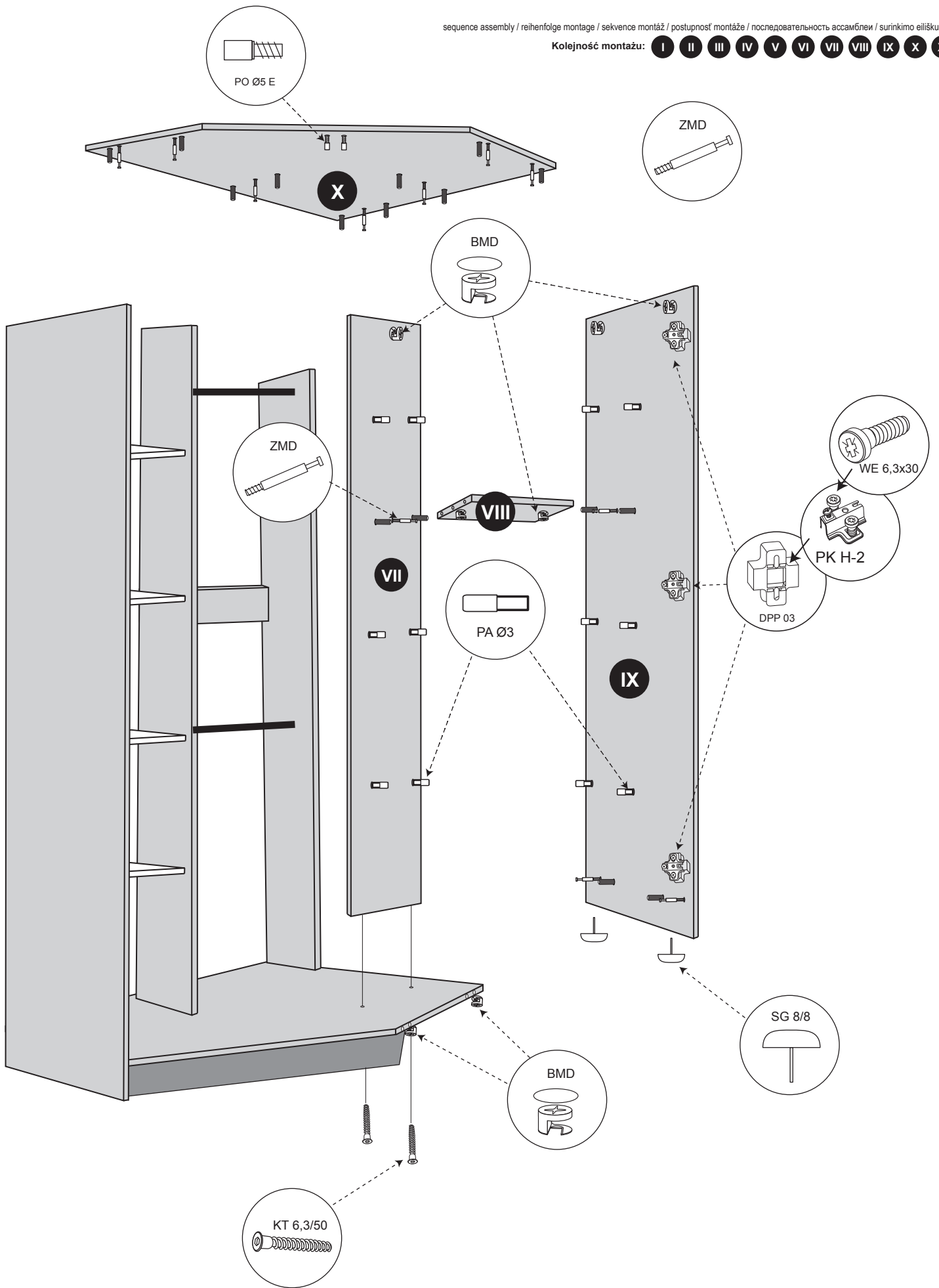

XI

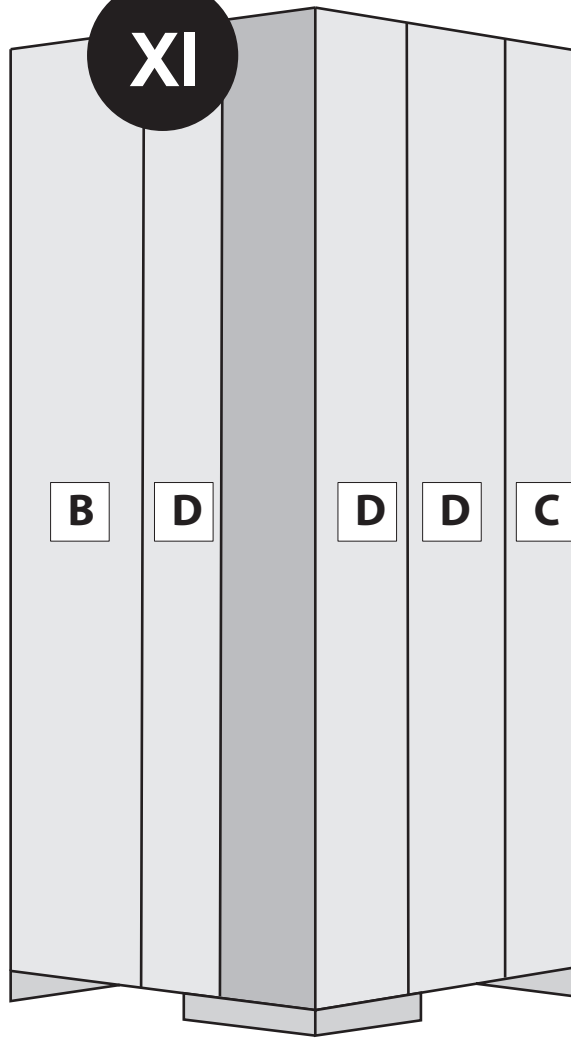

B 1908 x 337

C 1908 x 273

D 1908 x 307

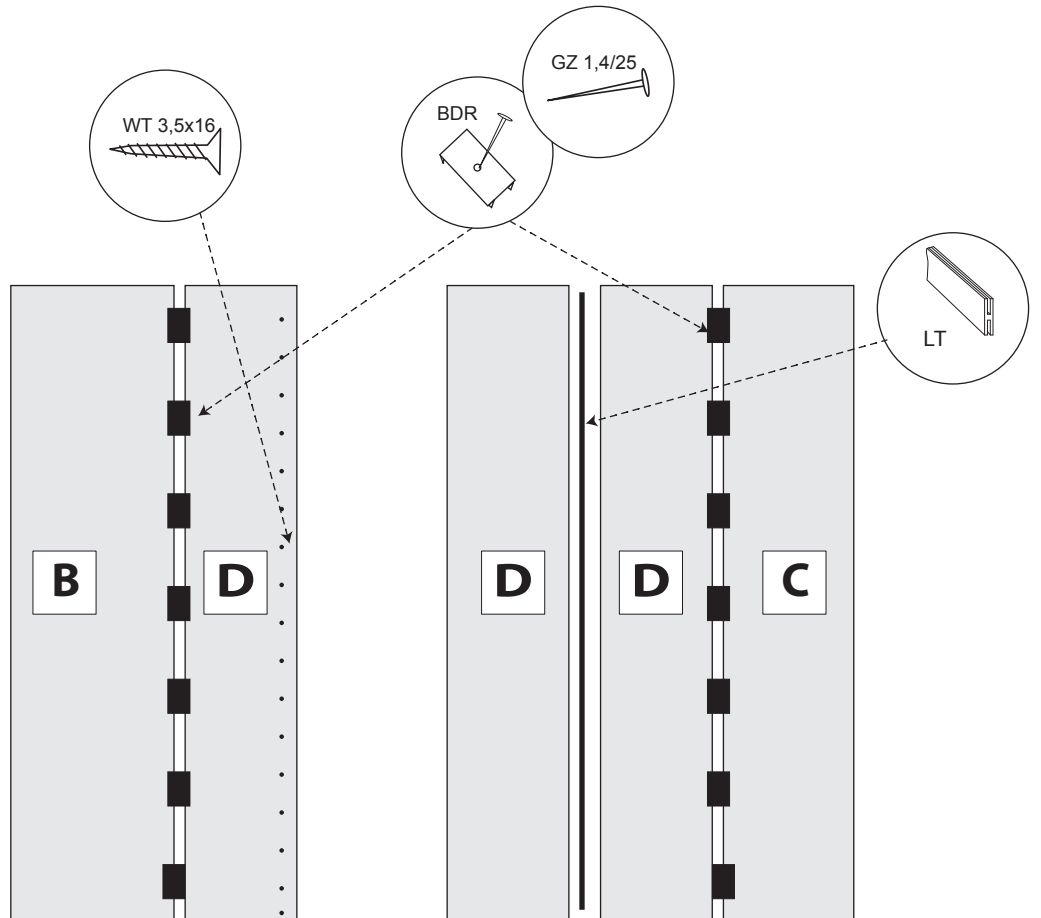

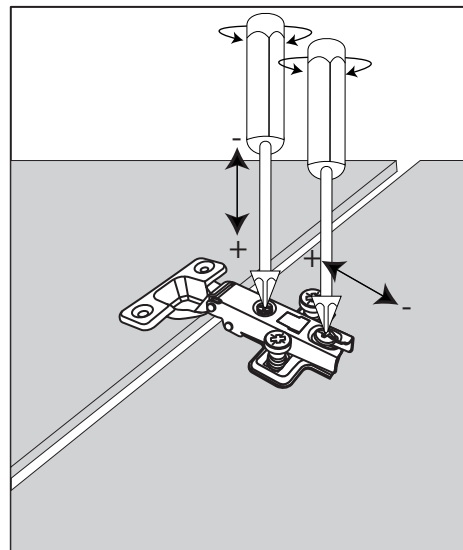
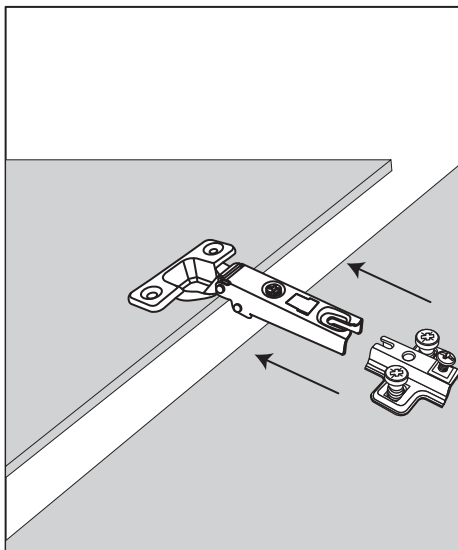
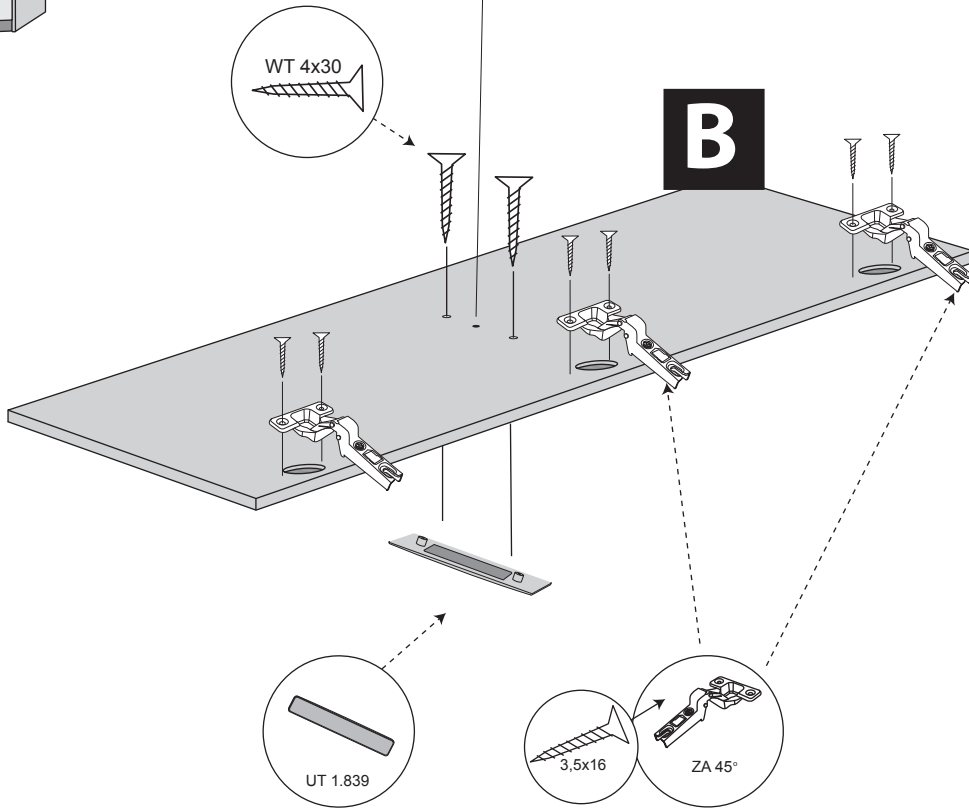
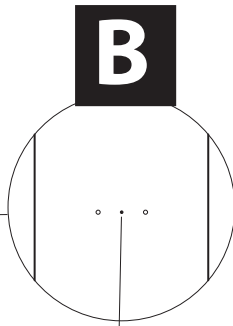
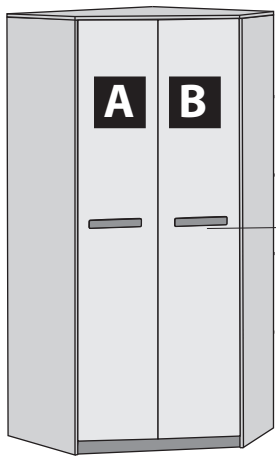



www.MLMEBLE.pl

GB D CZ SK RUS LT
assembly instructions / montageanleitung / montážní návod / montážny návod / инструкции по монтажу / surinkimo instrukcija



INSTRUKCJA MONTAŻU

BEST 09
 94 90 41

akcesoria / accessories / zubehör / příslušenství / prislušenstvo / аксессуары / furnitūra :

| | | | | | | | | | | |
|---------------------|----------------------|---|--|----------------|----------------|-----------------------|--------------------|---------------------|----------------|--------------------|
| x 30 KK 8/32 | x 8 KT 6,3/50 | x 60 GZ 1,4/25 | x 4 SG 8/8 | x 18 MD | x 6 ZAM | x 42 WT 3,5x16 | x 6 WT 4x30 | x 3 UT 1.839 | x 1 PKZ | x 3 PAL 350 |
| x 3 WS L 350 | x 2 LT | x 1 kluczyk / key / schlüssel / klíč / ključ / ключ / raktas | x 1 klej / glue / kleber / lepidlo / lepidlo / kлей / kljaj | | | | | | | |

do montażu potrzebne są:
 are needed for assembly:
 sind erforderlich für die montage:
 jsou potřebné pro montáž:
 sú potrebné pre montáž:
 которые необходимы для сборки:
 Surinkimui reikės:

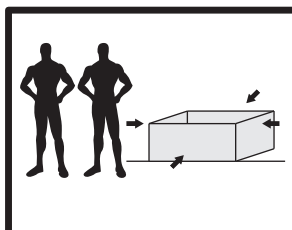
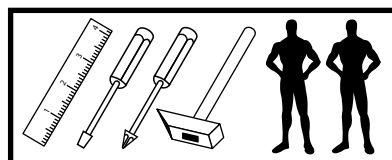

UWAGA ! - mebel należy składać w pozycji poziomej
WARNING! - furniture should be submitted in a horizontal position
WARNUNG! - Möbel sollten in einer horizontalen Position vorzulegen
POZOR! - Nábytek by měl být předložen ve vodorovné poloze
POZOR! - Nábytok by mal byť predložený vo vodorovnej polohe
ВНИМАНИЕ! - Мебель должна быть представлена в горизонтальном положении
DĚMESIO! - Baldą surenkame horizontalioje padėtyje

UWAGA ! - w pierwszej kolejności wbijamy akcesoria „KK” i „MD” w blaty oraz boki.
WARNING! - The first accessory sticks "KK" and "MD" in the tops and sides.
WARNUNG! - Die erste Accessoire-Sticks "KK" und "MD" in den Spitzen und an den Seiten.
POZOR! - První příslušenství holí "KK" a "MD" v korunách a boky.
POZOR! - Prvé príslušenstvo palíc "KK" a "MD" v korunách a boky.
ВНИМАНИЕ! - Первый аксессуаров палочки "KK" и "MD" по верхинам и по бокам.
DĚMESIO! - Pirmiausiai furnitūrą KK ir MD įkalame į stalviršį ir šonus.

| Nr/No | Szt/Qty |
|-------|---------|
| 1 | 1 |
| 2 | 1 |
| 3 | 1 |
| 4 | 2 |
| 5 | 3 |
| 6 | 1 |
| 7 | 8 |
| 8 | 1 |
| 9 | 2 |
| 10 | 4 |
| 11 | 2 |
| 12 | 3 |
| 13 | 3 |

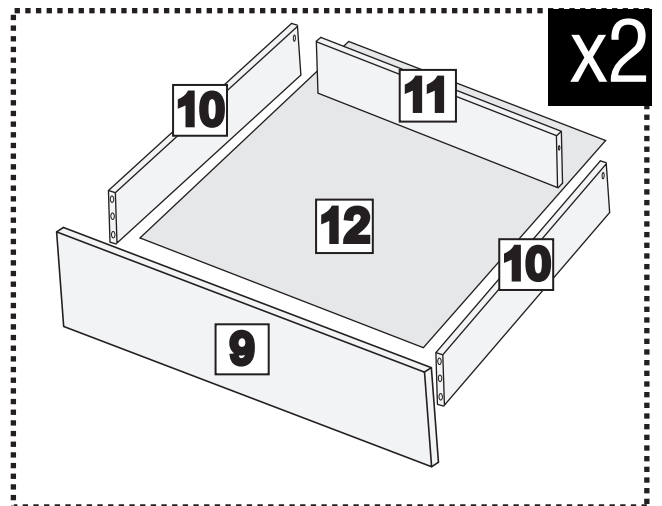
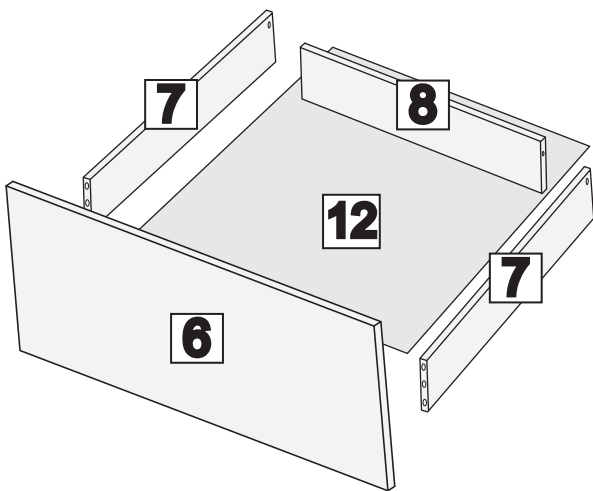
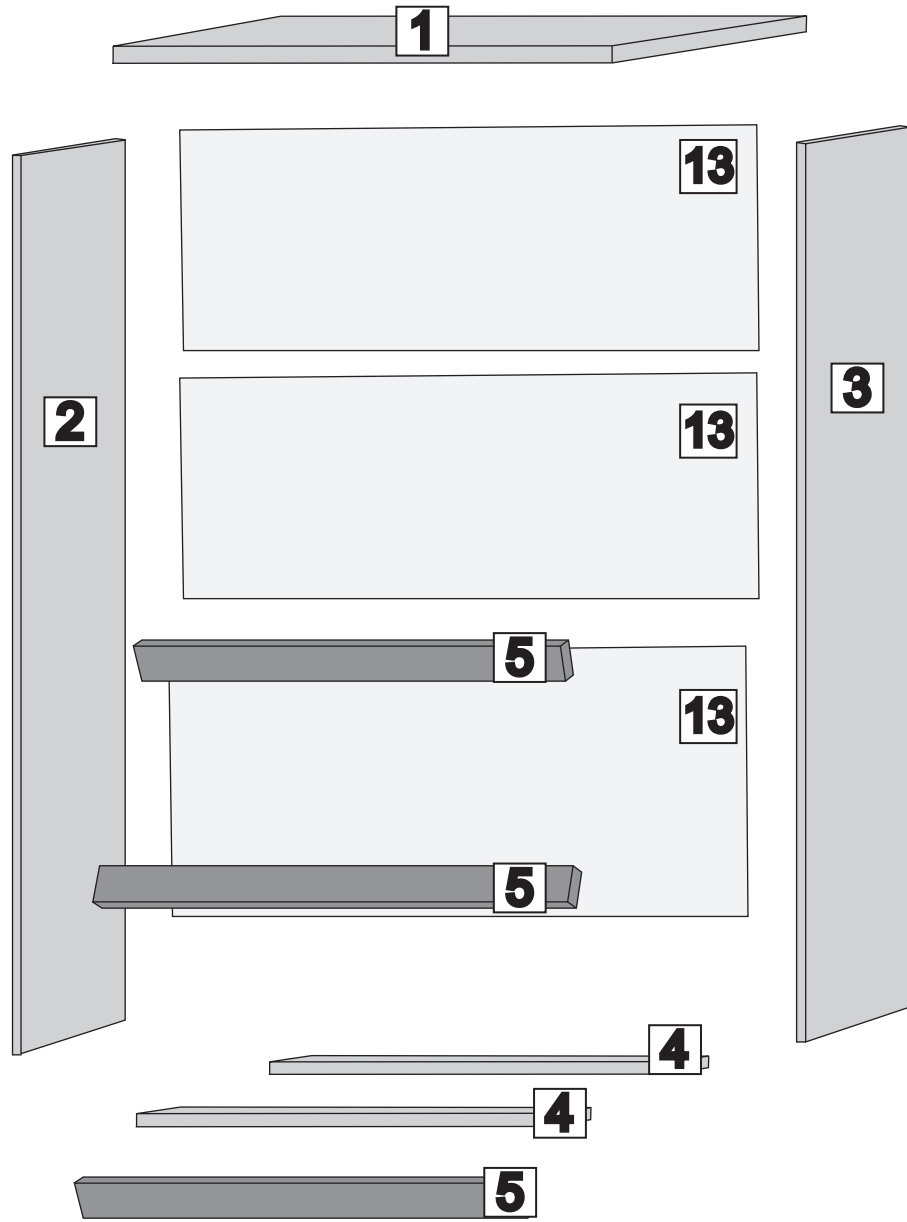

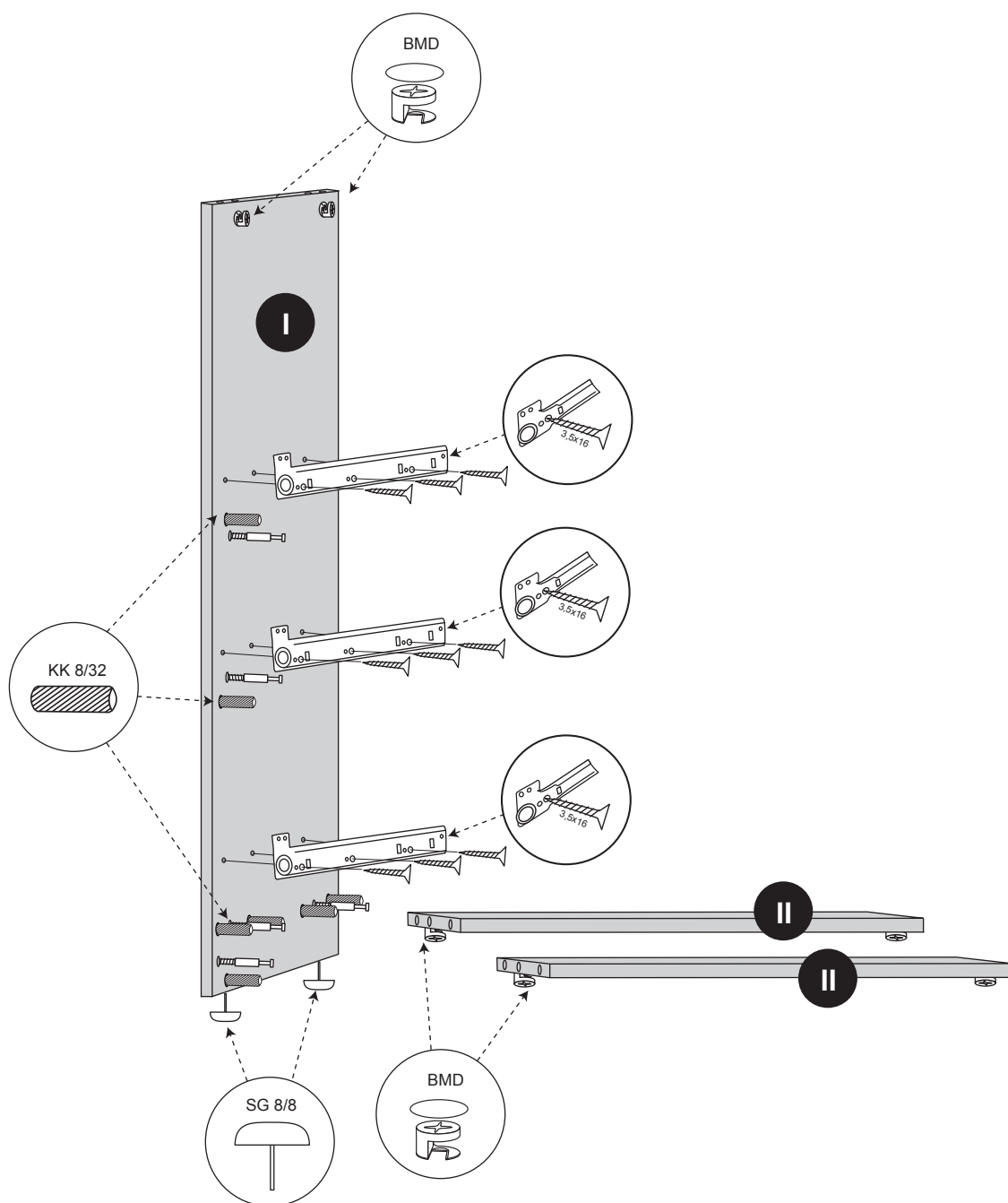
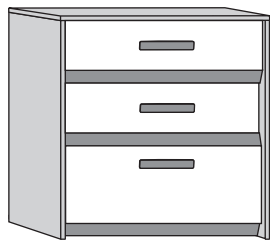

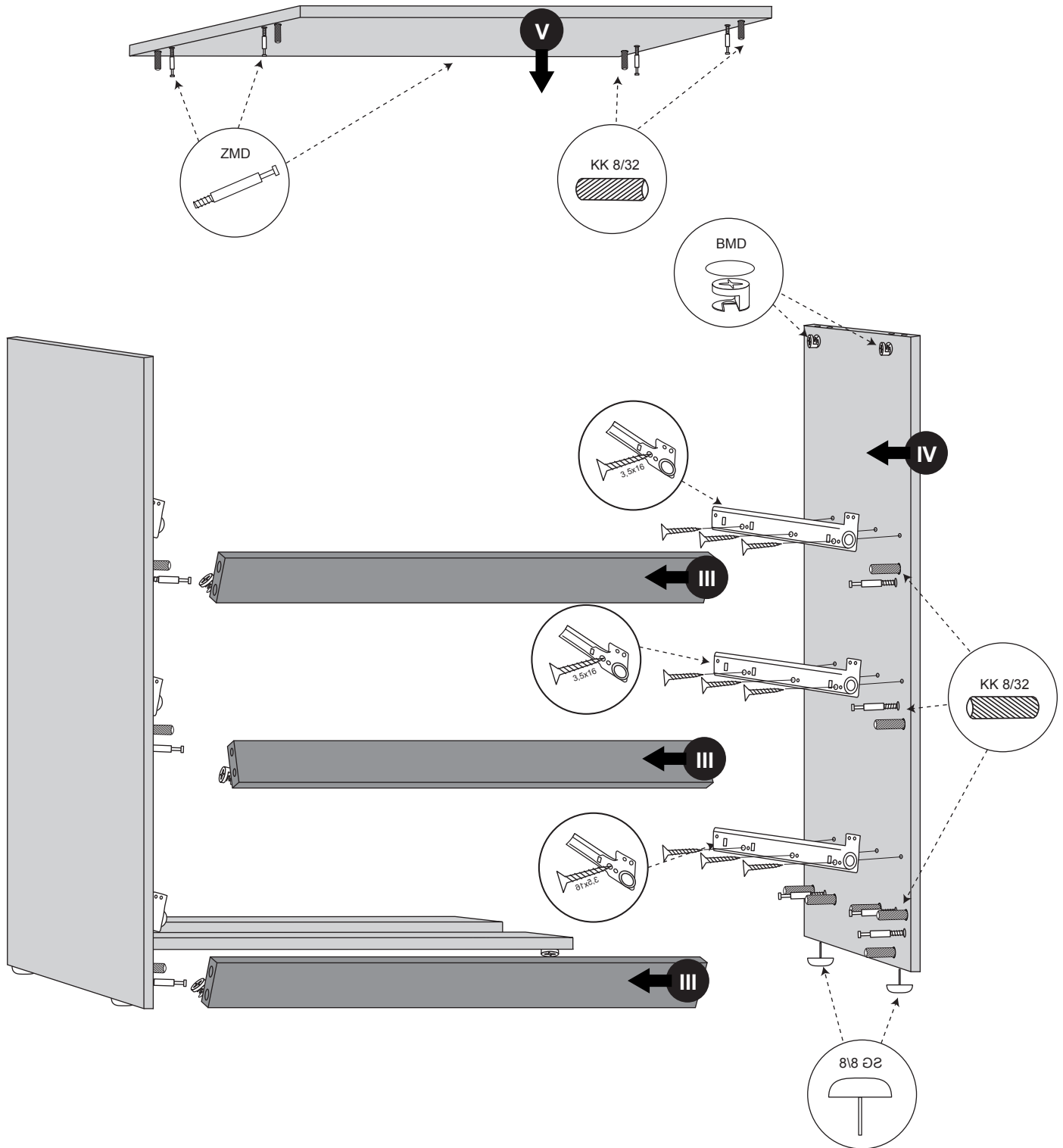
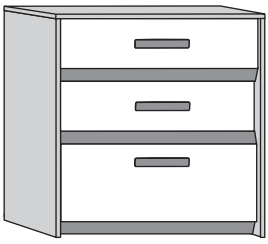

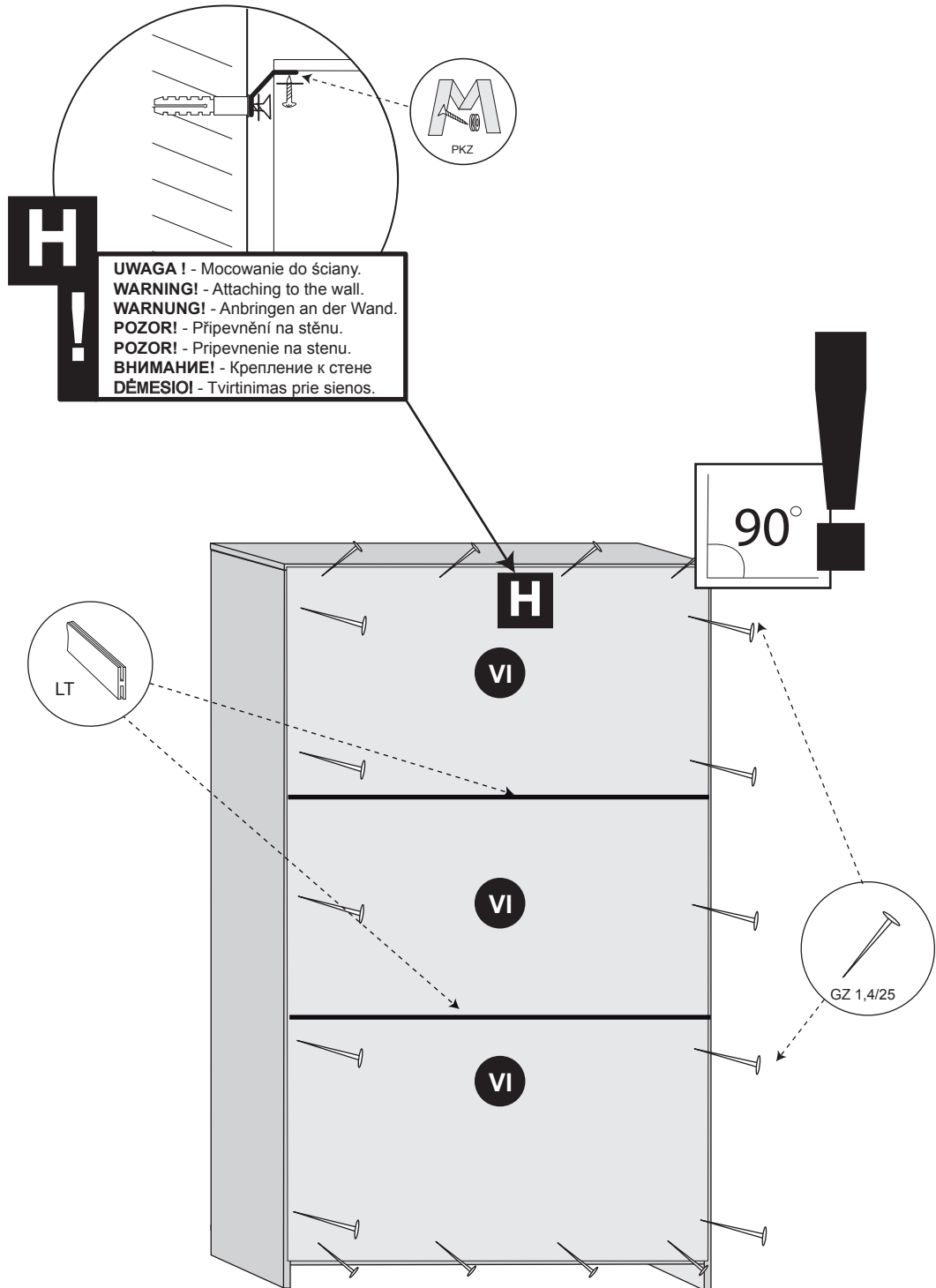
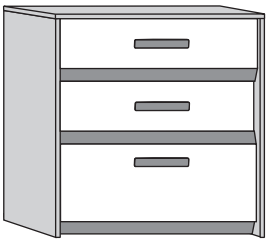

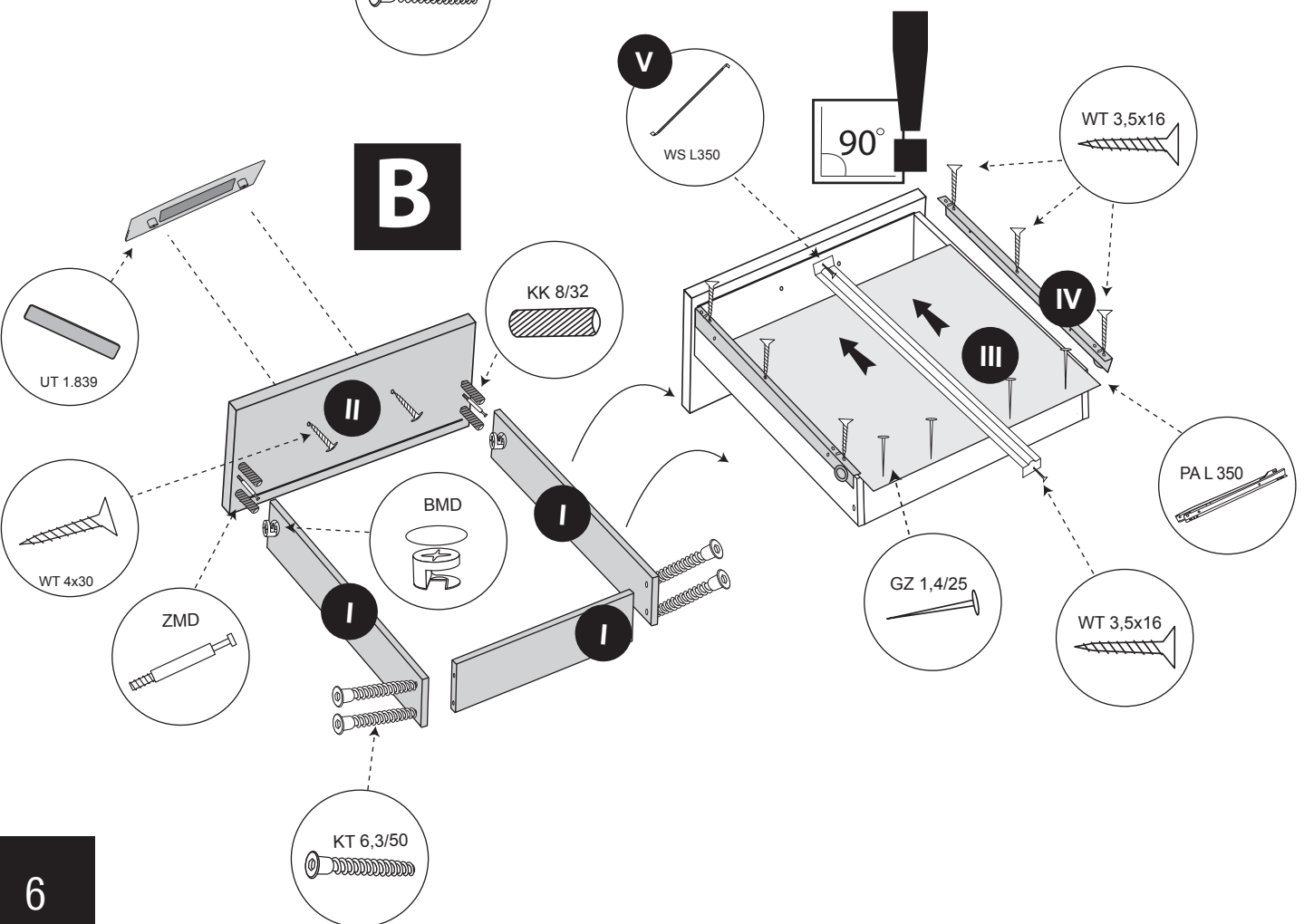
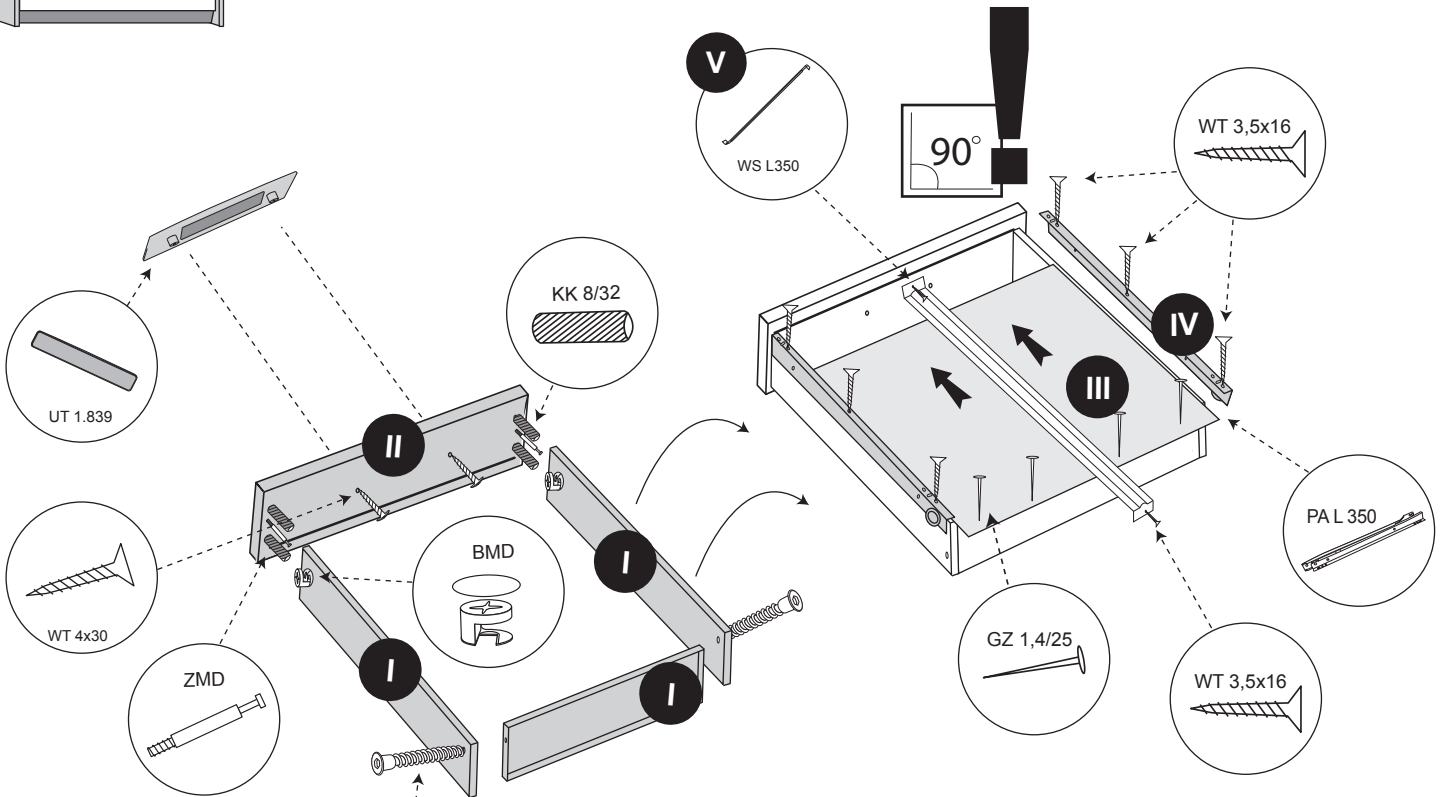
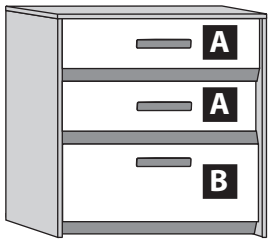

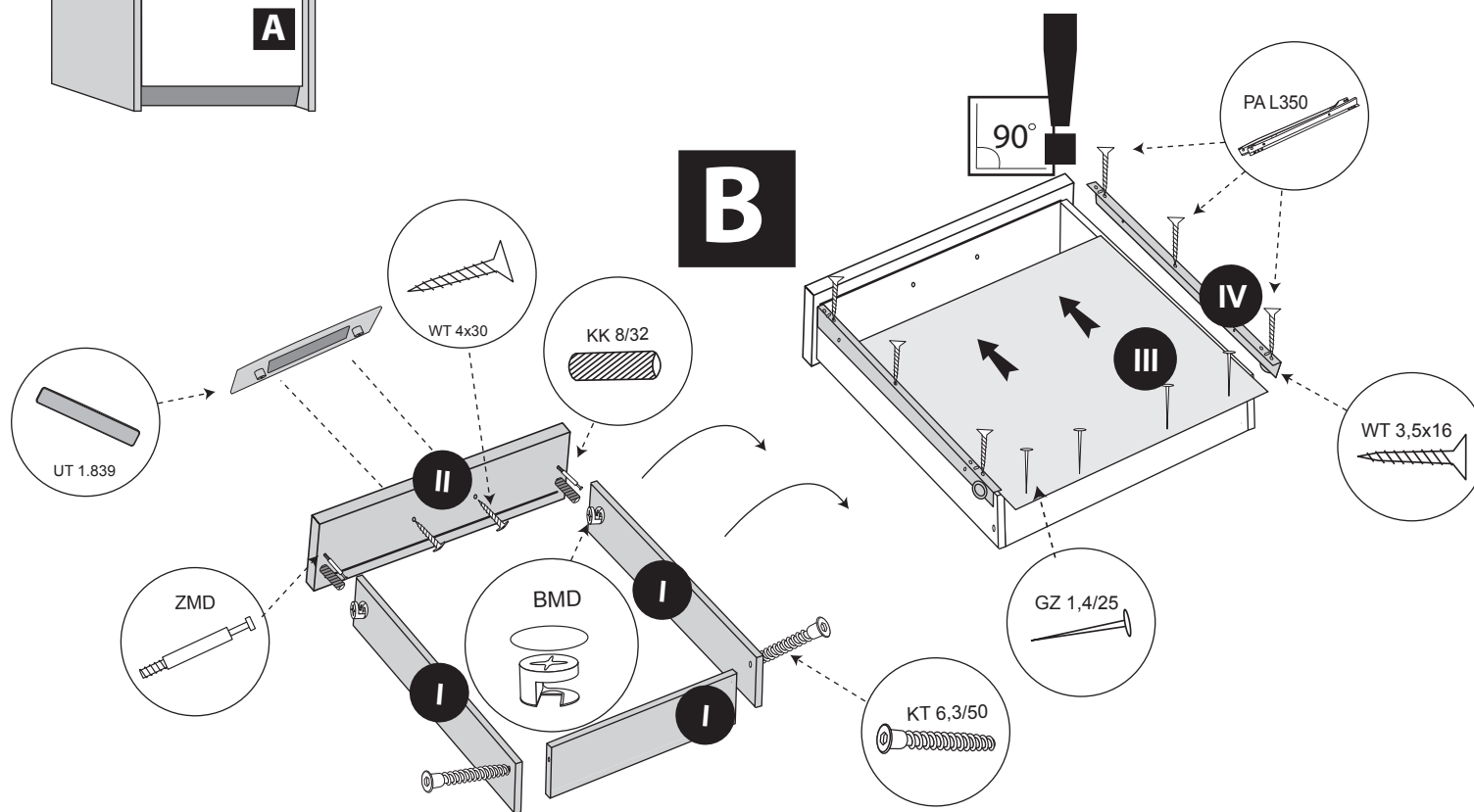
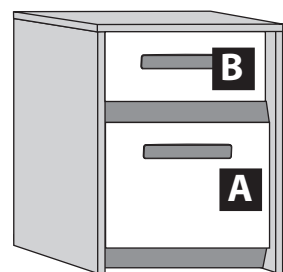

Possibility of assembling the right-left.
Möglichkeit der Montage der rechts-links.
Možnosť montáže vpravo-vlevo.
Возможность монтажа вправо-влево.
Galima padaryti pusę kairę arba dešinę.

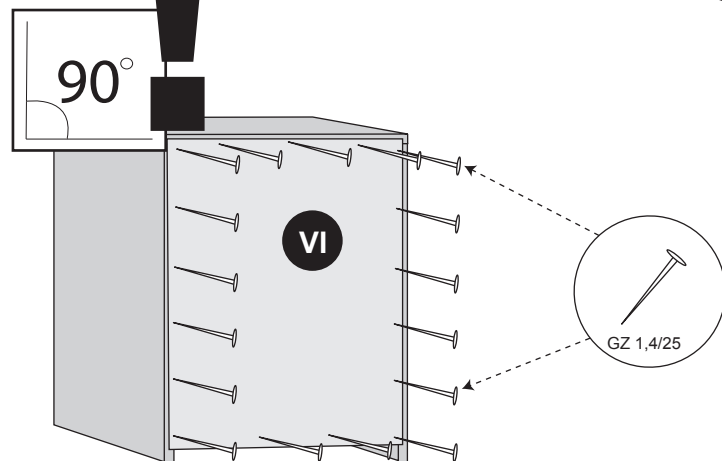
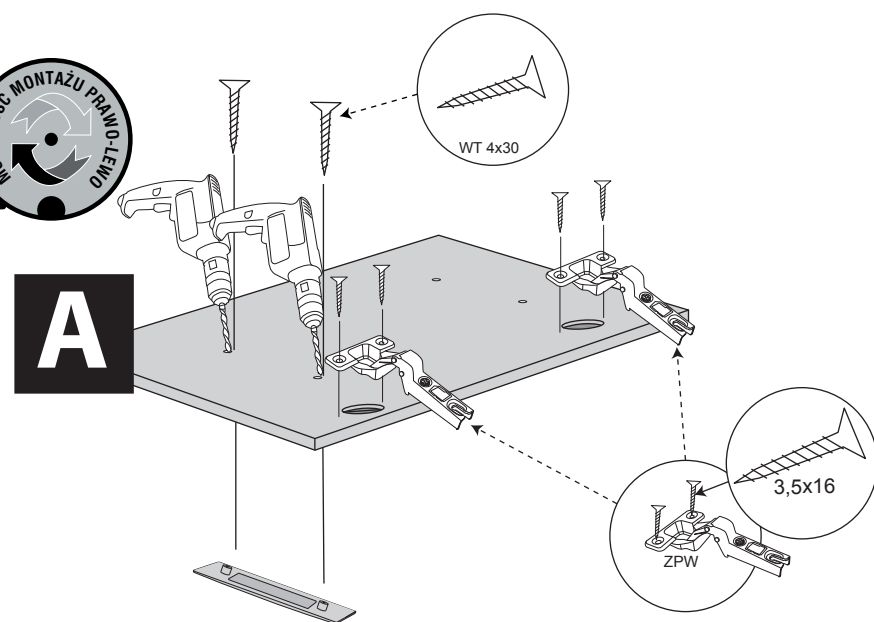

www.MLMEUBLE.pl

assembly instructions / montageanleitung / montážní návod / montážny návod / инструкции по монтажу / surinkimo instrukcija

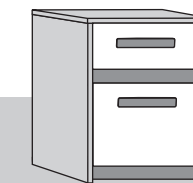

INSTRUKCJA MONTAŻU

BEST 11
↑57 →40 ↘41

akcesoria / accessories / zubehör / příslušenství / príslušenstvo / аксесуары / furnitūra :

| | | | | | | | | | | |
|-----------------|------------------|--|--|------------|------------|-------------------|----------------|------------|---------------|------------------|
| x 14 KK 8/32 | x 2 KT 6,3/50 | x 40 GZ 1,4/25 | x 4 SG 8/8 | x 14 MD | x 2 ZAM | x 16 WT 3,5x16 | x 4 WT 4x30 | x 2 ZPW | x 2 PK H-4 | x 4 WE 6,3x13 |
| x 1 PAL 350 | x 2 UT 1.839 | x 1 klucz / key / schlüssel / klíč / kľúč / ключ / raktas | x 1 klej / glue / kleber / lepidlo / lepidlo / kлей / kljaj | | | | | | | |

do montażu potrzebne są:
are needed for assembly:
sind erforderlich für die montage:
jsou potřebné pro montáž:
sú potrebné pre montáž:
которые необходимы для сборки:
Surinkimui reikės:

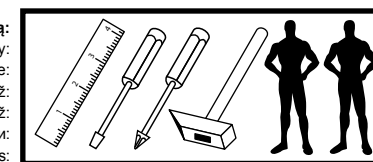

! UWAGA ! - w pierwszej kolejności wbijamy akcesoria „KK” i „MD” w blaty oraz boki.
WARNING! - The first accessory sticks "KK" and "MD" in the tops and sides.
WARNUNG! - Die erste Accessoire-Sticks "KK" und "MD" in den Spitzen und an den Seiten.
POZOR! - První příslušenství holí "KK" a "MD" v korunách a boky.
POZOR! - Prvé príslušenstvo palíc "KK" a "MD" v korunách a boky.
ВНИМАНИЕ! - Первый аксессуаров палочки "KK" и "MD" по вершинам и по бокам.
DĚMESIO! - Pirmiausiai furnitūrą KK ir MD įkalame į stalviršį ir šonus.

| Nr/No | Szt/Qty |
|-------|---------|
| 1 | 1 |
| 2 | 1 |
| 3 | 1 |
| 4 | 1 |
| 5 | 2 |
| 6 | 1 |
| 7 | 1 |
| 8 | 2 |
| 9 | 1 |
| 10 | 1 |
| 11 | 1 |

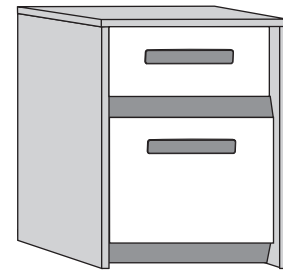
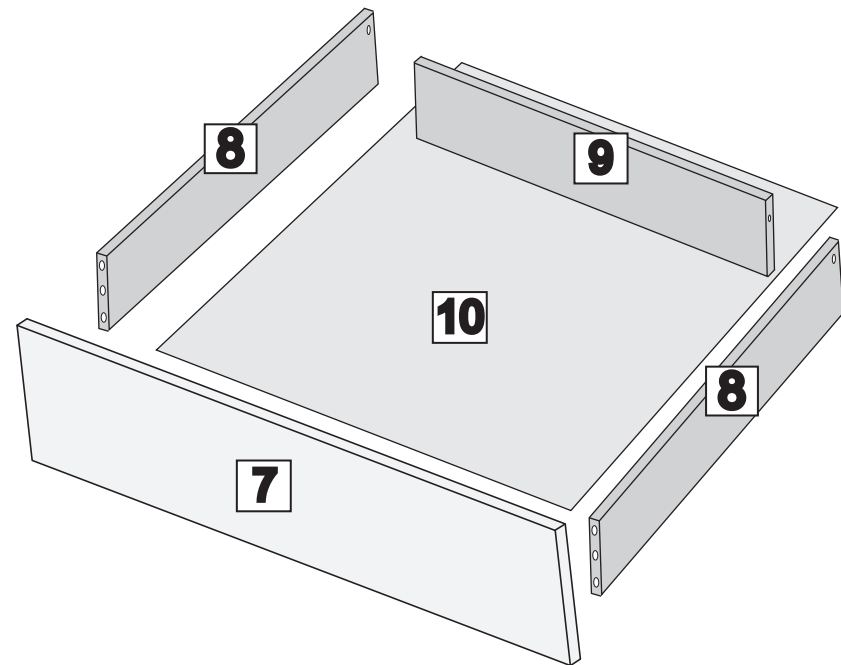
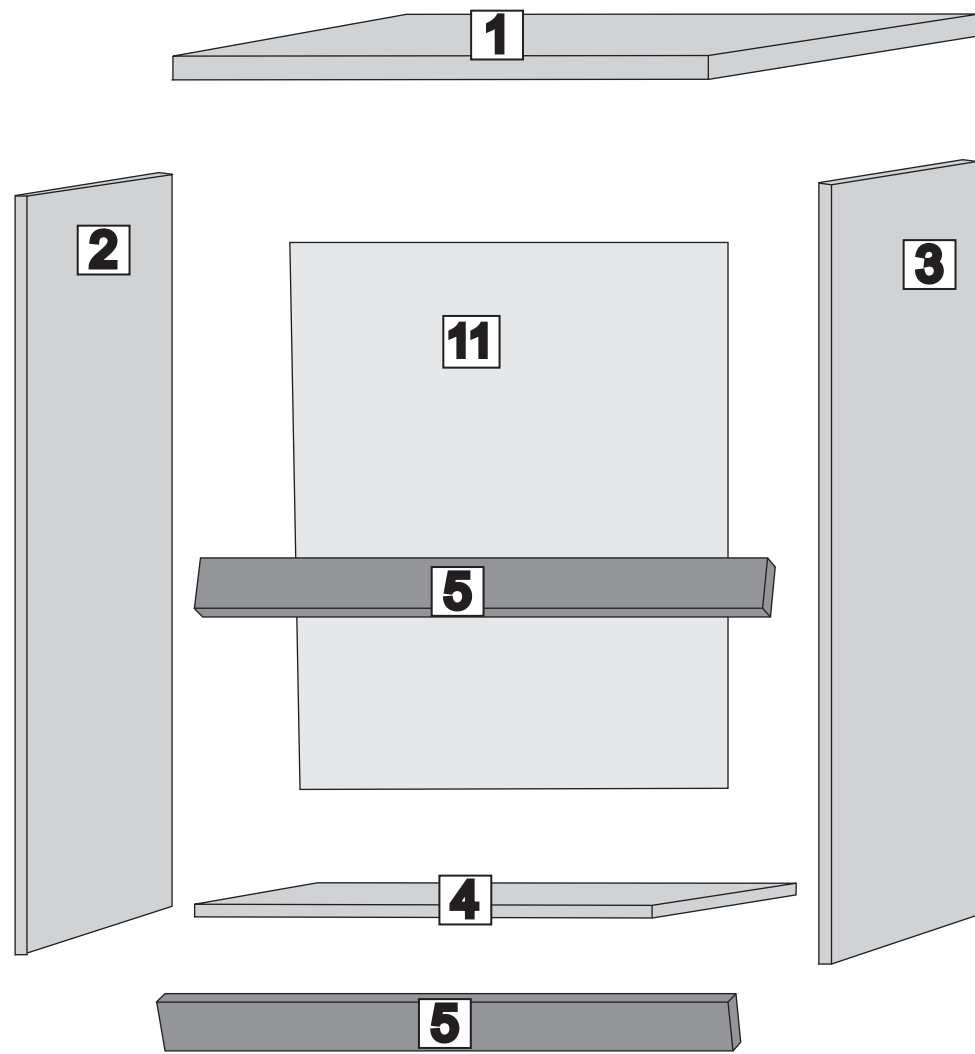
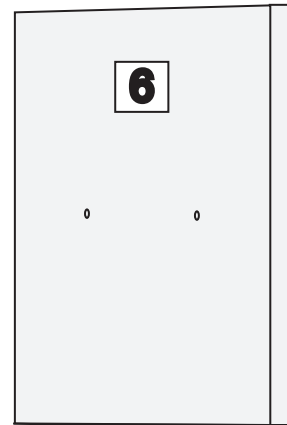

sequence assembly / reihenfolge montage / sekvence montáž / postupnosť montáže / последовательность сборки / surinkimo eiliškumas

Kolejność montażu: I II III IV V VI

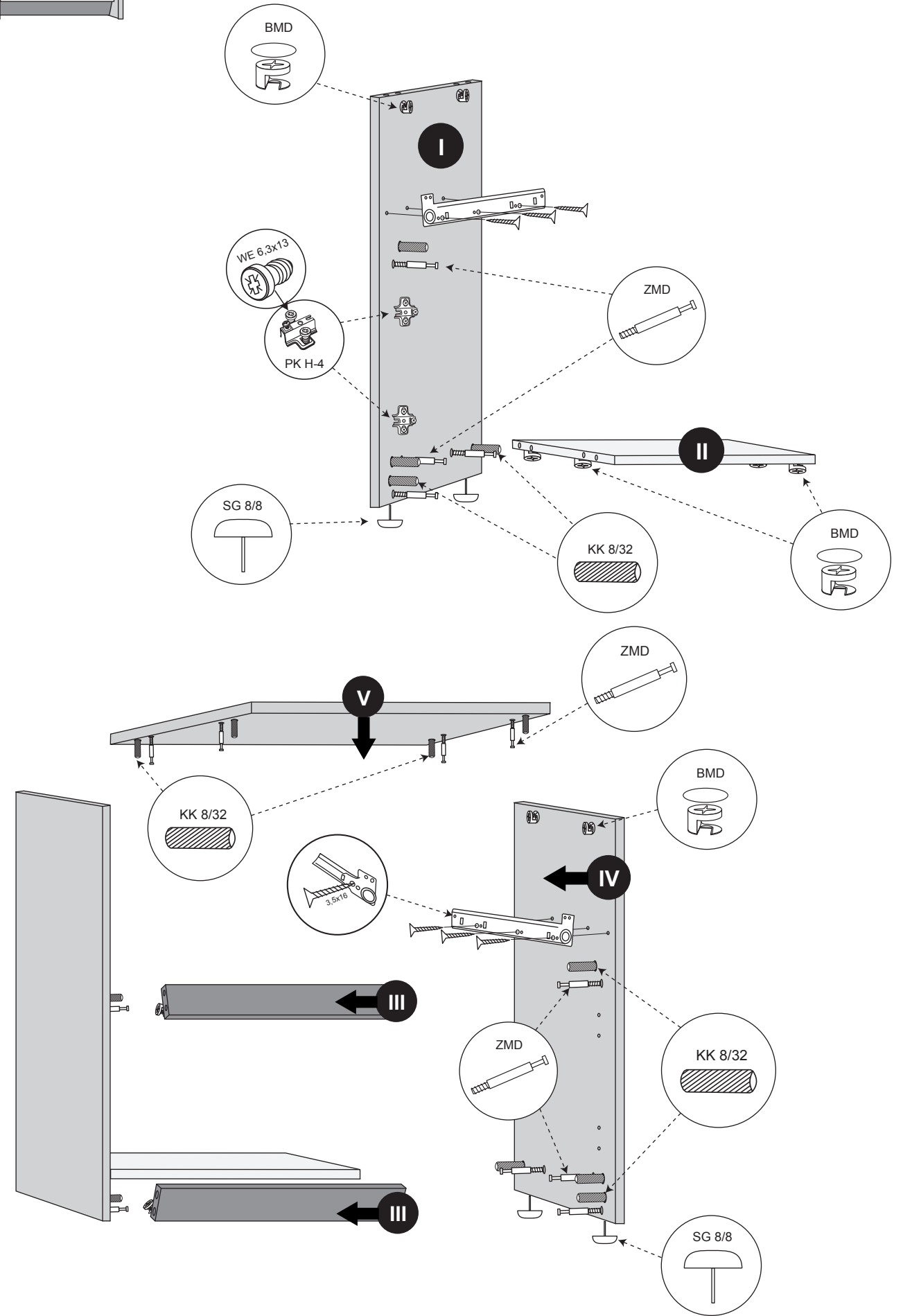

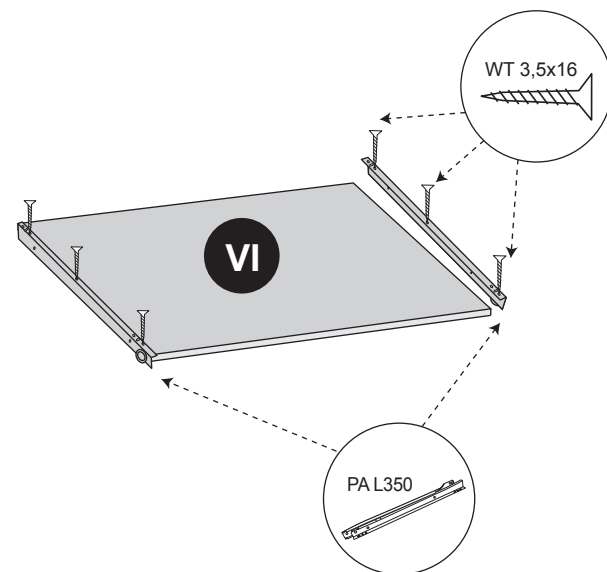
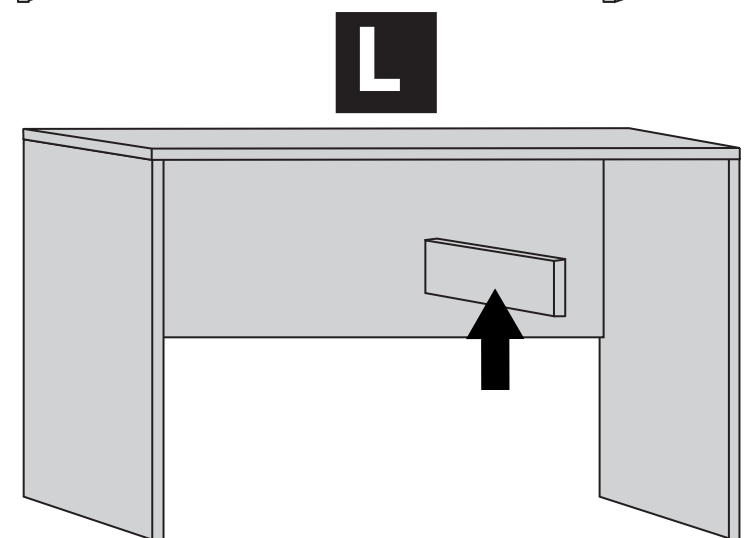
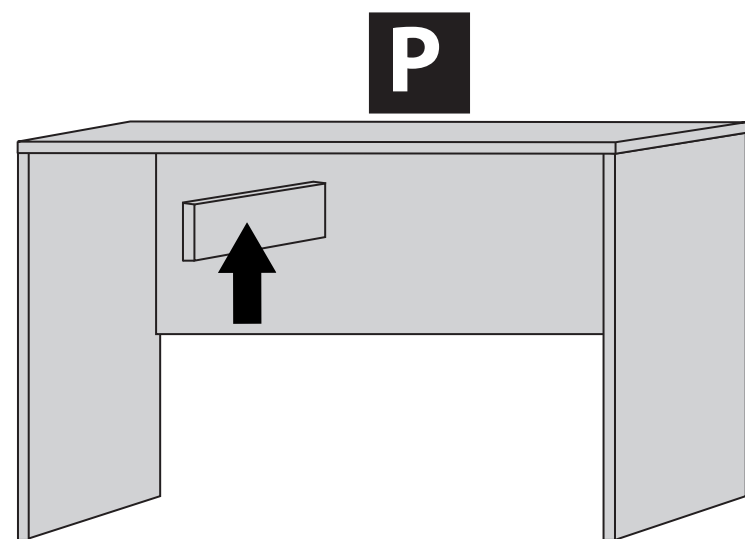
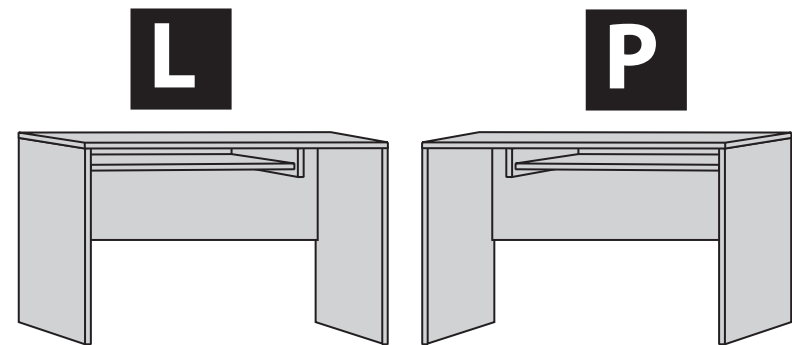

www.MLMEBLE.pl

GB D CZ SK RU LT
assembly instructions / montageanleitung / montážní návod / montážny návod / инструкции по монтажу / surinkimo instrukcija



INSTRUKCJA MONTAŻU

BEST 12
↑76 →120 ↘55

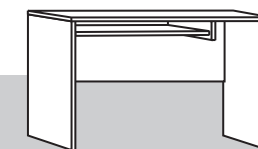

akcesoria / accessories / zubehör / příslušenství / prislušenstvo / аксесуары / furnitūra :

| | | | | | | | | |
|-----------------|------------------|-------------|------------|---------------|-------------------|----------------|--|---|
| x 10 KK 8/32 | x 1 KT 6,3/50 | x 2 ZA N | x 10 MD | x 4 SG 8/8 | x 12 WT 3,5x16 | x 1 PA L350 | x 1 kluczyk / key / schlüssel / klíč / kluč / kľov / raktas | x 1 klej / glue / kleber / lepidlo / lepidlo / klij / klijai |
|-----------------|------------------|-------------|------------|---------------|-------------------|----------------|--|---|

do montażu potrzebne są:
are needed for assembly:
sind erforderlich für die montage:
jsou potřebné pro montáž:
sú potrebné pre montáž:
которые необходимы для сборки:
Surinkimui reikės:

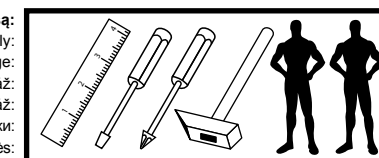

! UWAGA! - W pierwszej kolejności wbijamy akcesoria „KK” i „MD” w blaty oraz boki i montujemy prowadnice.
WARNING! - In the first place should be driven accessories "KK" and "MD" in the tops and sides and guides.
WARNUNG! - In erster Linie sollte Accessoires "KK" und "MD" in den Wipfeln und an den Seiten und Guides gefahren werden.
POZOR! - V první řadě by měl být tažen příslušenství "KK" a "MD" v korunách a po stranách a průvodec.
POZOR! - V prvom rade by mal byť ťahaný príslušenstvo "KK" a "MD" v korunách a po stranách a sprievodcov.
ВНИМАНИЕ! - В первую очередь следует руководствоваться аксесуары "KK" и "MD", на вершинах и по бокам и руководства.
DĚMESIO! - Pirmiausiai furnitūrą KK ir MD įkalame į stalviršį ir šonus ir prisukame bėgelius.

| Nr/No | Szt/Qty |
|-------|---------|
| 1 | 1 |
| 2 | 1 |
| 3 | 1 |
| 4 | 1 |
| 5 | 1 |
| 6 | 1 |

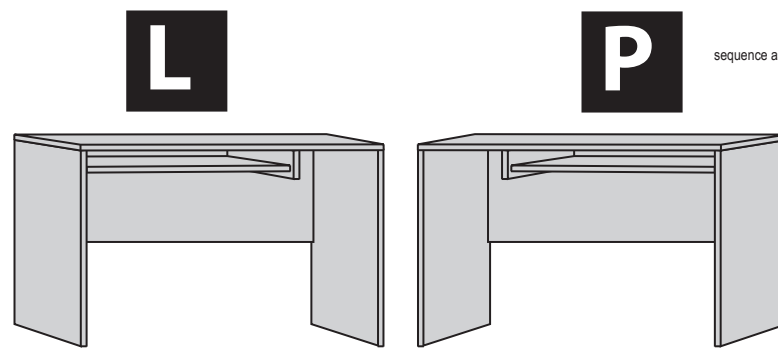
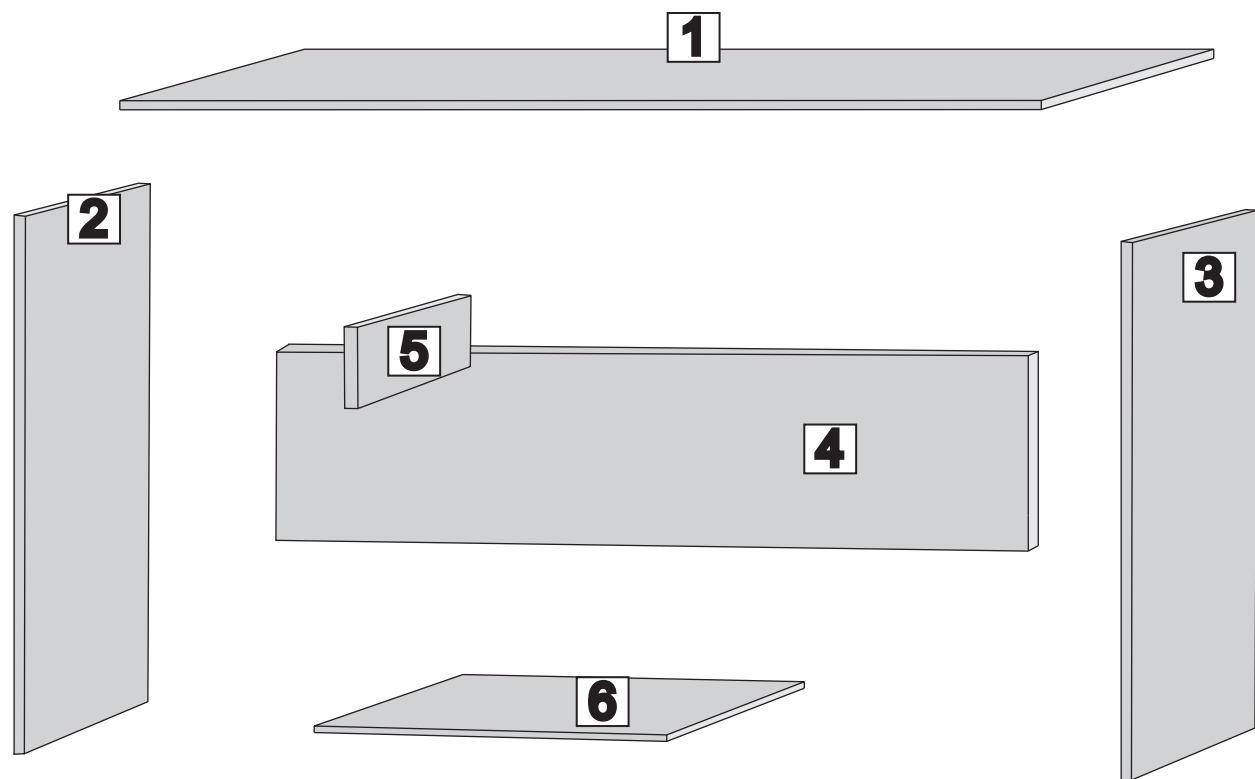

sequence assembly / reihenfolge montage / sekvence montáž / postupnosť montáže / последовательность сборки / surinkimo eiliškumas

Kolejność montażu: I II III IV V VI VII

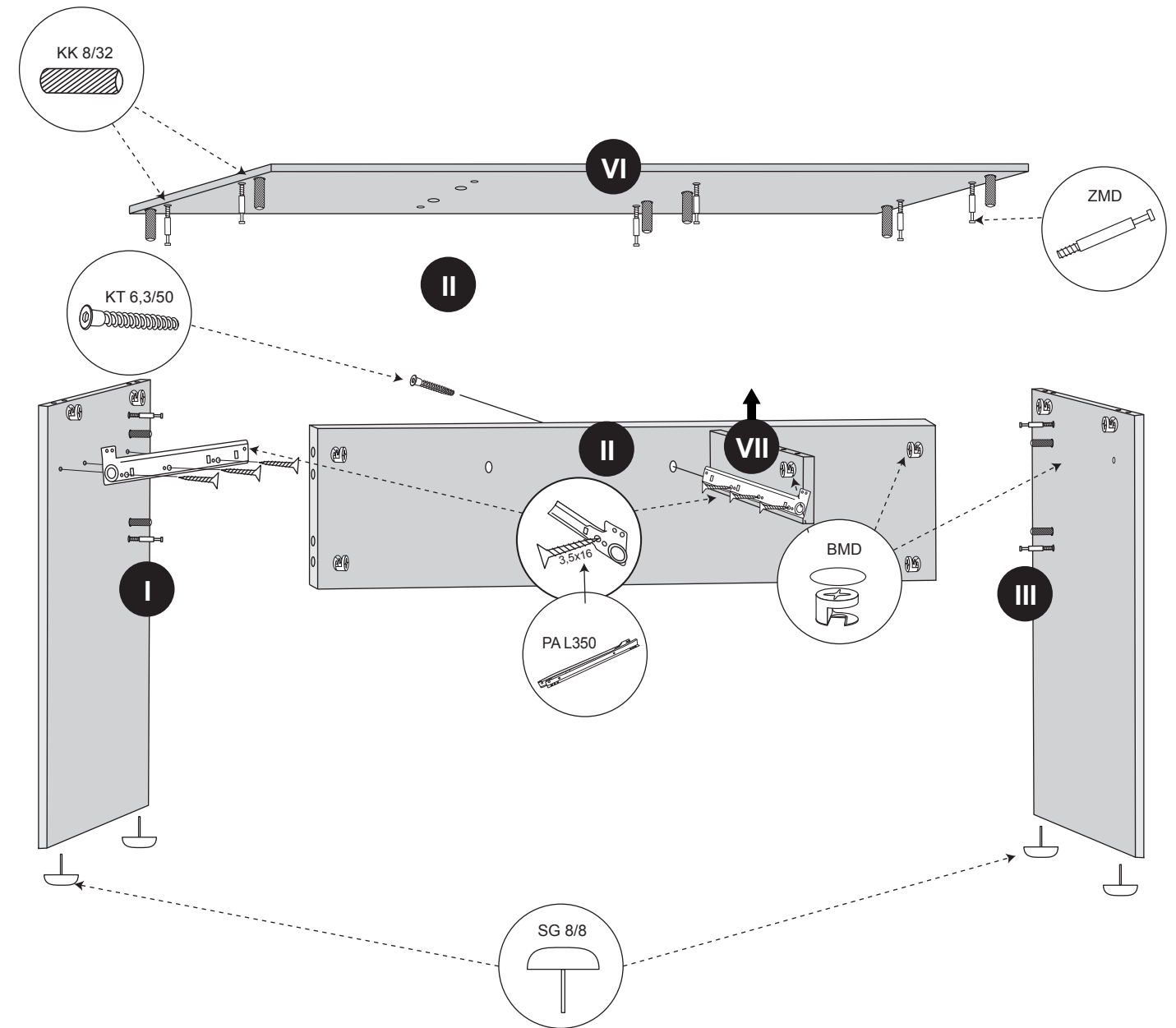

Kolejność montażu: I II III IV

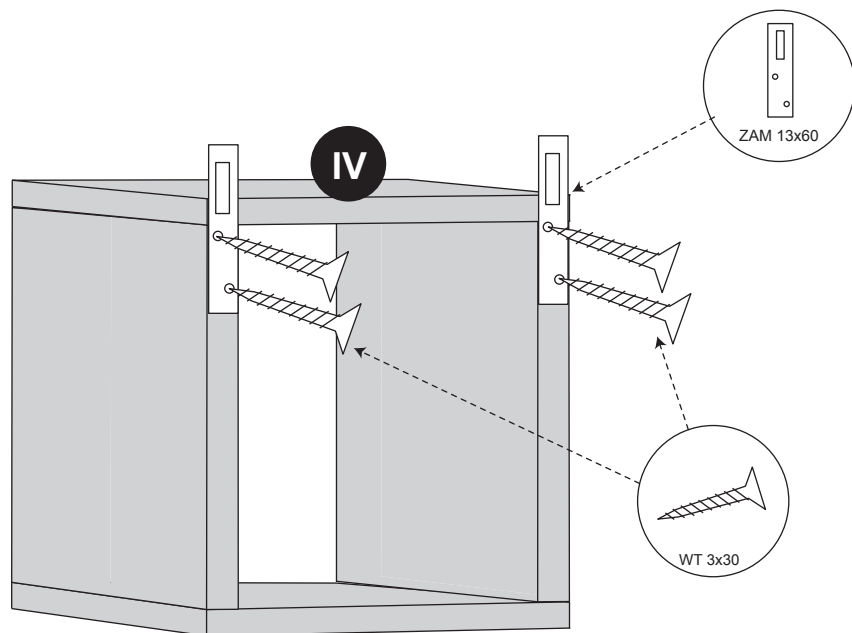

www.MLMEBLE.pl

GB assembly instructions / D. montageanleitung / CZ montážní návod / SK montážny návod / RUS инструкции по монтажу / LT surinkimo instrukcija



INSTRUKCJA MONTAŻU

BEST 15
↑ 29 → 29 ↗ 20

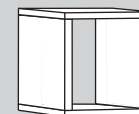

akcesoria / accessories / zubehör / příslušenství / prislušenstvo / аксессуары / furnitūra :

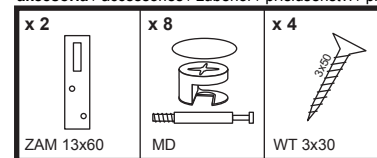

do montażu potrzebne są:
are needed for assembly:
sind erforderlich für die montage:
jsou potřebné pro montáž:
sú potrebné pre montáž:
которые необходимы для сборки:
Surinkimui reikės:

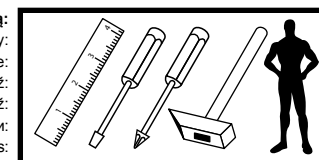

| Nr/No | Szt/Qty |
|-------|---------|
| 1 | 2 |
| 2 | 2 |

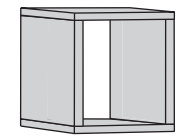
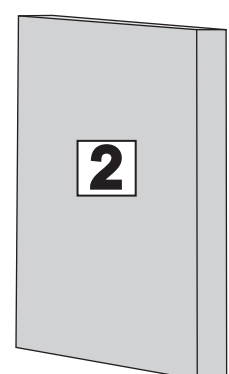
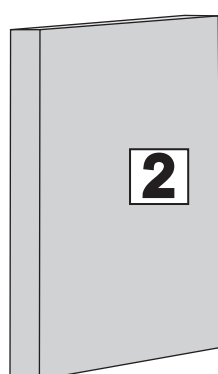
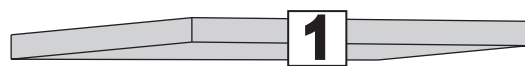

sequence assembly / reihenfolge montage / sekvence montáž / postupnost' montáže / последовательность ассамбли / surinkimo eiliškumas

Kolejność montażu: I II III IV

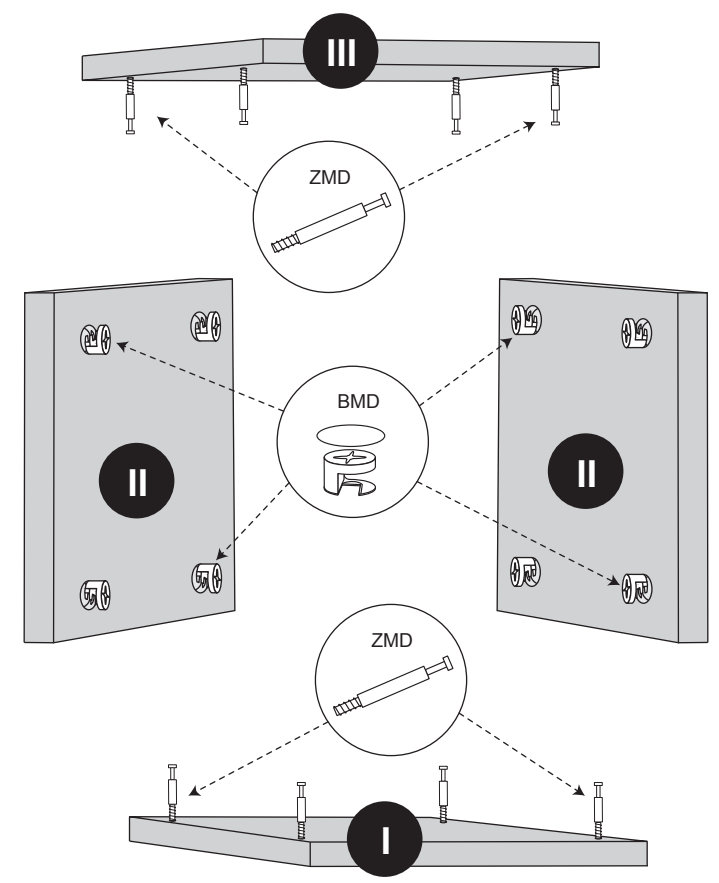

1

2