

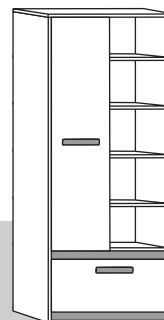

www.MLMEBLE.pl

GB D CZ SK RUS LT  
assembly instructions / montageanleitung / montážní návod / montážny návod / инструкции по монтажу / surinkimo instrukcija



## INSTRUKCJA MONTAŻU

**BEST 03**  
 199 80 41

akcesoria / accessories / zubehör / příslušenství / prislušenstvo / аксессуары / furnitūra :

x 30  KK 8/32	x 6  KT 6,3/50	x 80  GZ 1,4/25	x 4  SG 8/8	x 26  MD	x 8  ZAM	x 8  ZAM	x 24  PA Ø5	x 20  WT 3,5x16	x 4  WT 4x30	x 3  ZPW
x 3  PK H-4	x 6  WE 6,3x13	x 12  BDP	x 2  UT 1.839	x 1  PKZ	x 1  PAL 350	x 1  WS L 350	x 1  kluczyk / key / schlüssel / kľúč / ключ / raktas	x 1  klej / glue / kleber / lepidlo / lepido / kņei / kljaj		

**do montaży potrzebne są:**  
 are needed for assembly:  
 sind erforderlich für die montage:  
 jsou potřebné pro montáž:  
 sú potrebné pre montáž:  
 которые необходимы для сборки:  
 Surinkimui reikės:

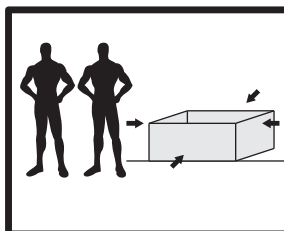
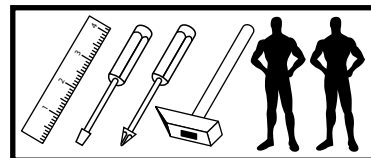

**UWAGA !** - mebel należy składać w pozycji poziomej  
**WARNING!** - furniture should be submitted in a horizontal position  
**WARNUNG!** - Möbel sollten in einer horizontalen Position vorzulegen  
**POZOR!** - Nábytek by měl být předložen ve vodorovné poloze  
**POZOR!** - Nábytok by mal byť predložený vo vodorovnej polohe  
**ВНИМАНИЕ!** - Мебель должна быть представлена в горизонтальном положении  
**DĚMESIO!** - Baldą surenkame horizontalioje padėtyje

**UWAGA !** - w pierwszej kolejności wbijamy akcesoria „KK” i „MD” w blaty oraz boki.  
**WARNING!** - The first accessory sticks "KK" and "MD" in the tops and sides.  
**WARNUNG!** - Die erste Accessoire-Sticks "KK" und "MD" in den Spitzen und an den Seiten.  
**POZOR!** - První příslušenství holí "KK" a "MD" v korunách a boky.  
**POZOR!** - Prvé príslušenstvo palíc "KK" a "MD" v korunách a boky.  
**ВНИМАНИЕ!** - Первый аксессуаров палочки "KK" и "MD" по верхинам и по бокам.  
**DĚMESIO!** - Pirmiausiai furnitūrą KK ir MD įkalame į stalviršį ir šonus.

Nr/No	Szt/Qty
1	1
2	1
3	1
4	3
5	1
6	1
7	3
8	1
9	1
10	2
11	2
12	1
13	1
14	2
15	1
16	1
17	1
18	1

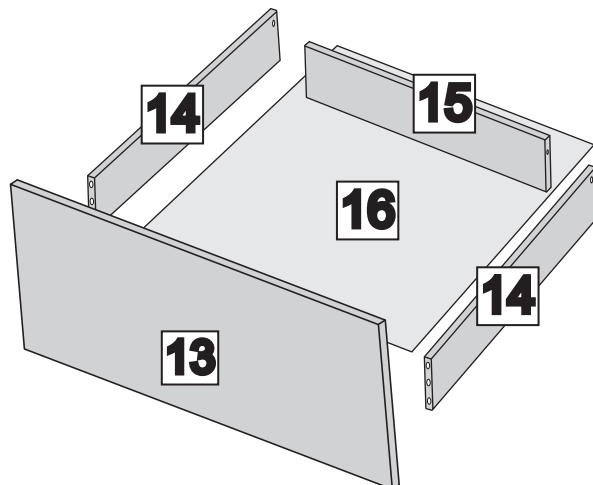
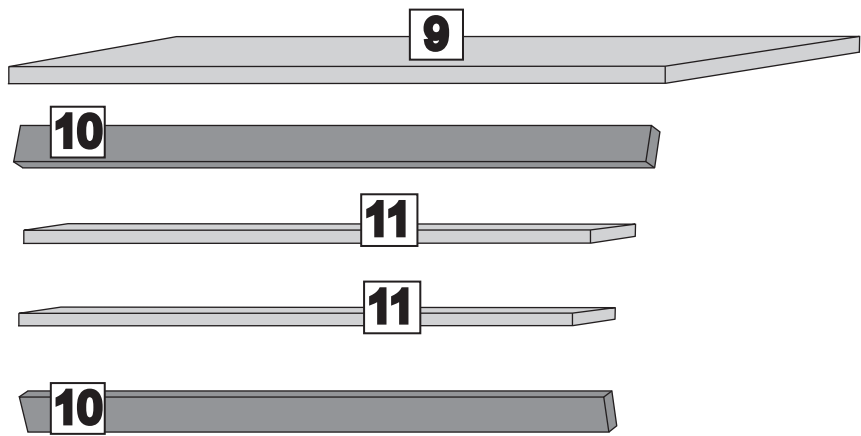
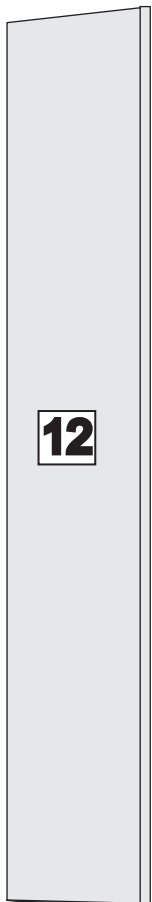
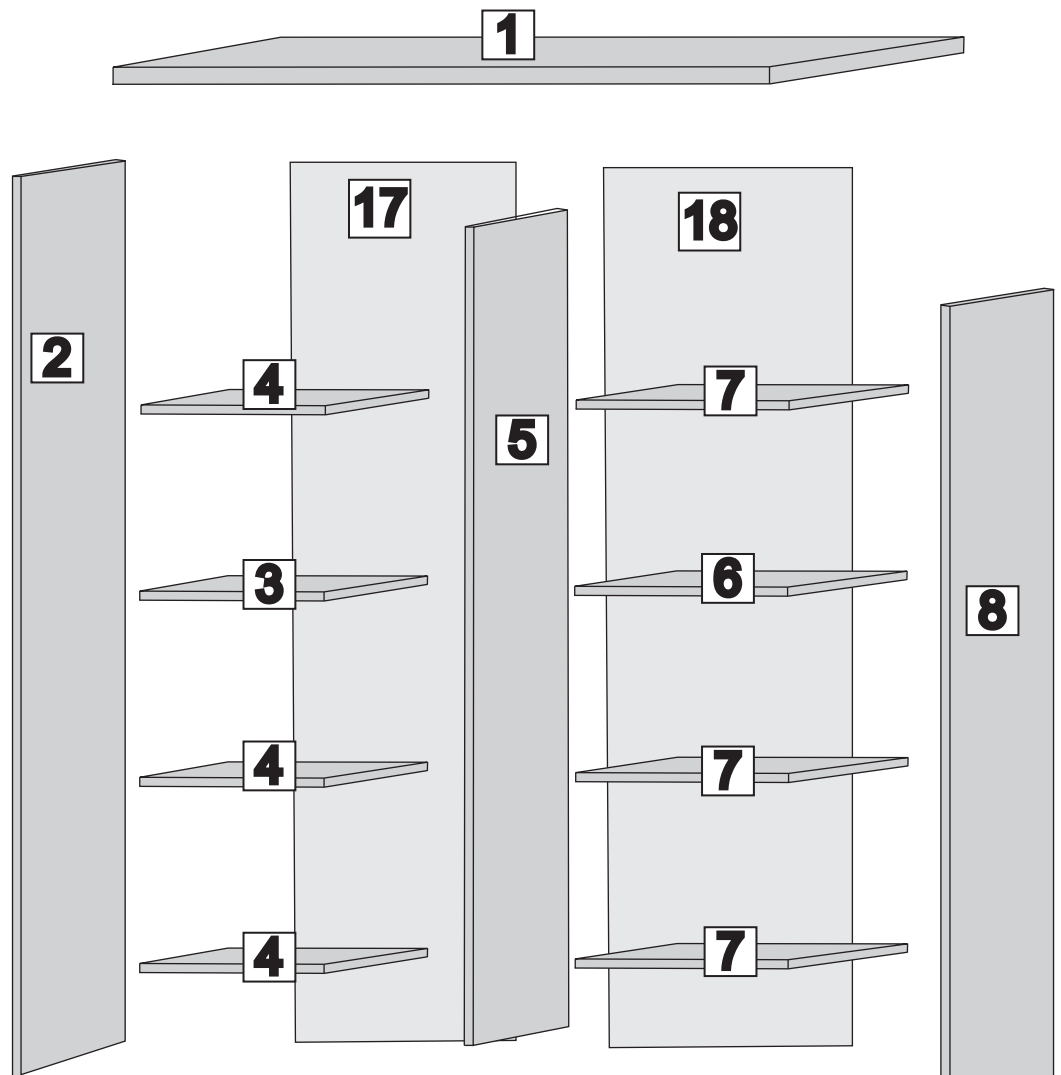

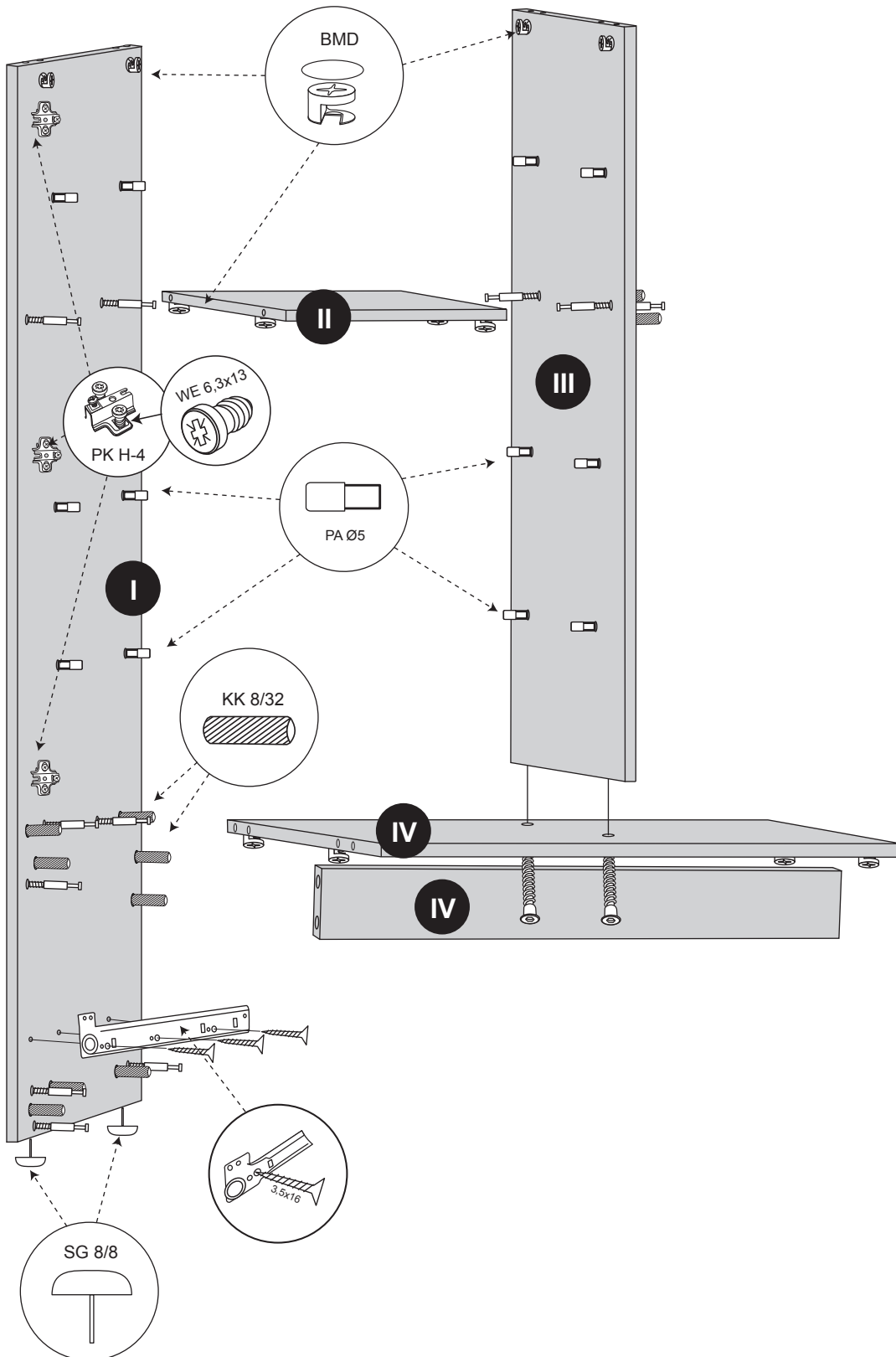
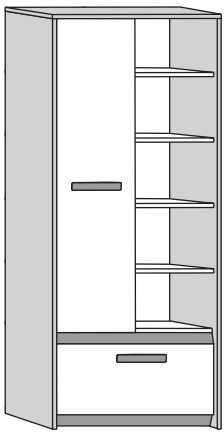

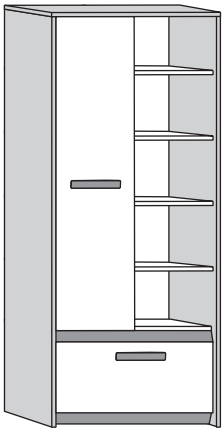

sequence assembly / reihenfolge montage / sekvenca montáž / postupnosť montáže / последовательность ассамблеи / surinkimo eiliškumas

Kolejność montażu: I II III IV V VI VII VIII

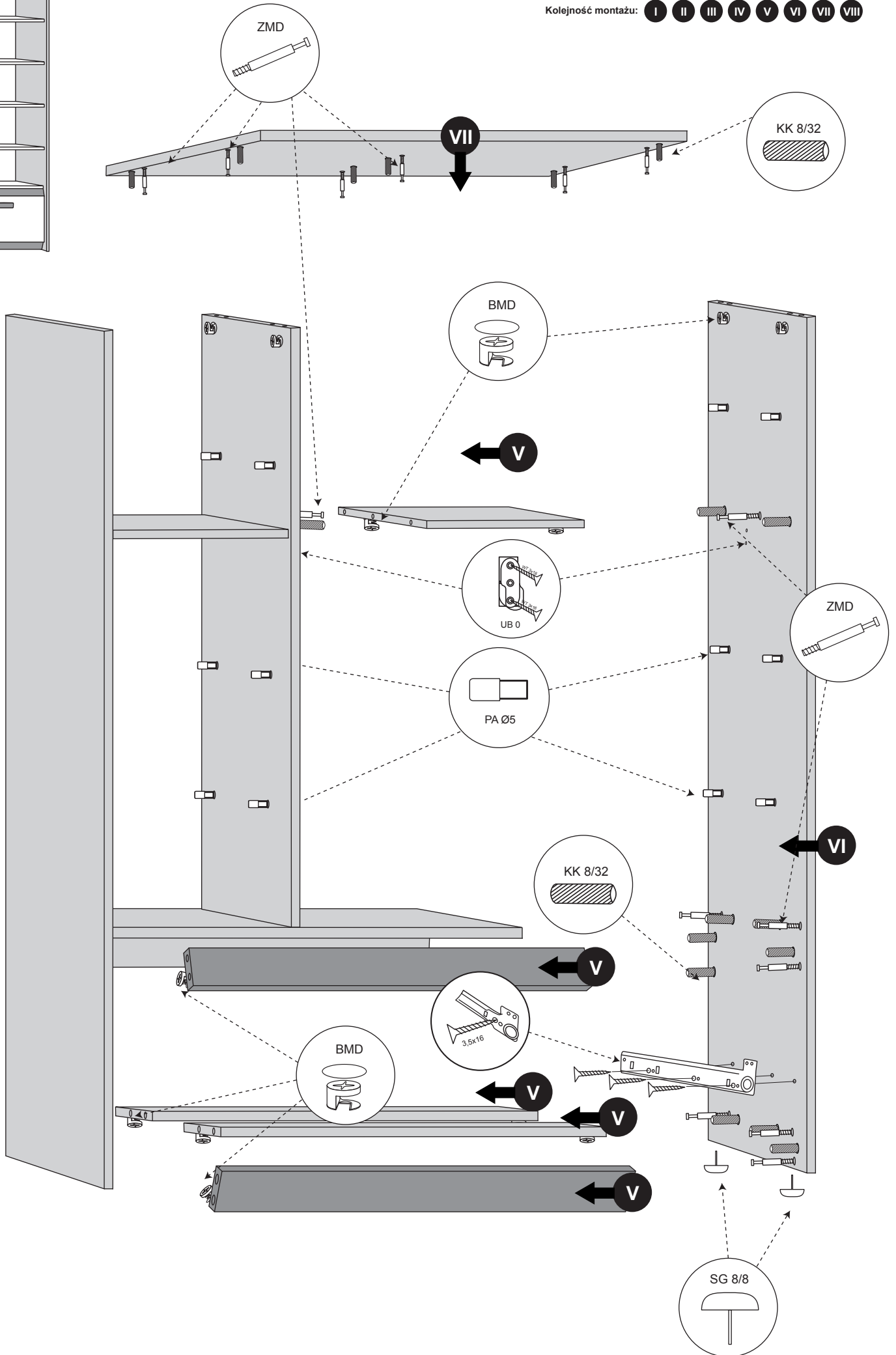

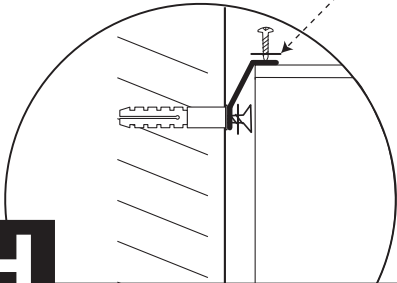

**UWAGA !** - Mocowanie do ściany.  
**WARNING!** - Attaching to the wall.  
**WARNUNG!** - Anbringen an der Wand.  
**POZOR!** - Připevnění na stěnu.  
**POZOR!** - Připevnenie na stenu.  
**ВНИМАНИЕ!** - Крепление к стене  
**DĒMESIO!** - Tvirtinimas prie sienos.

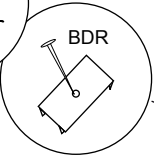
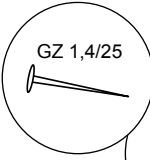
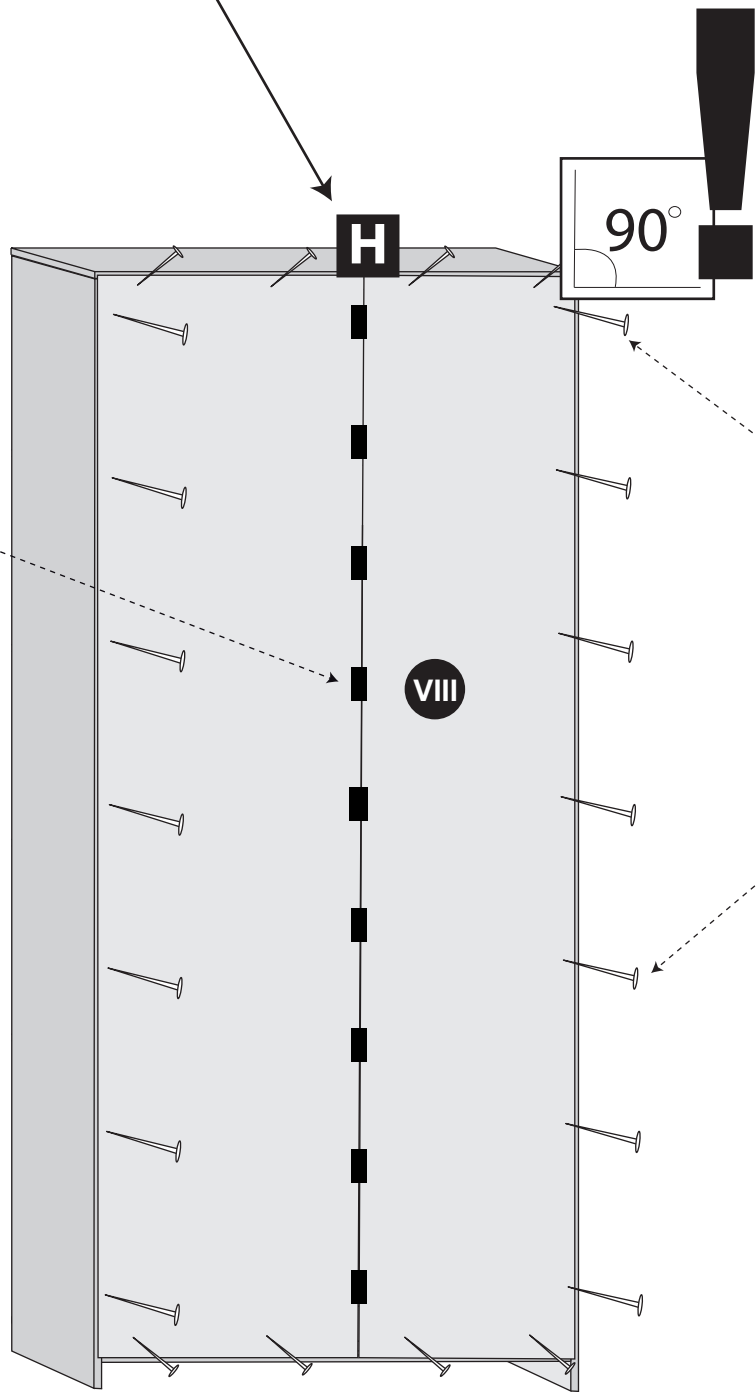

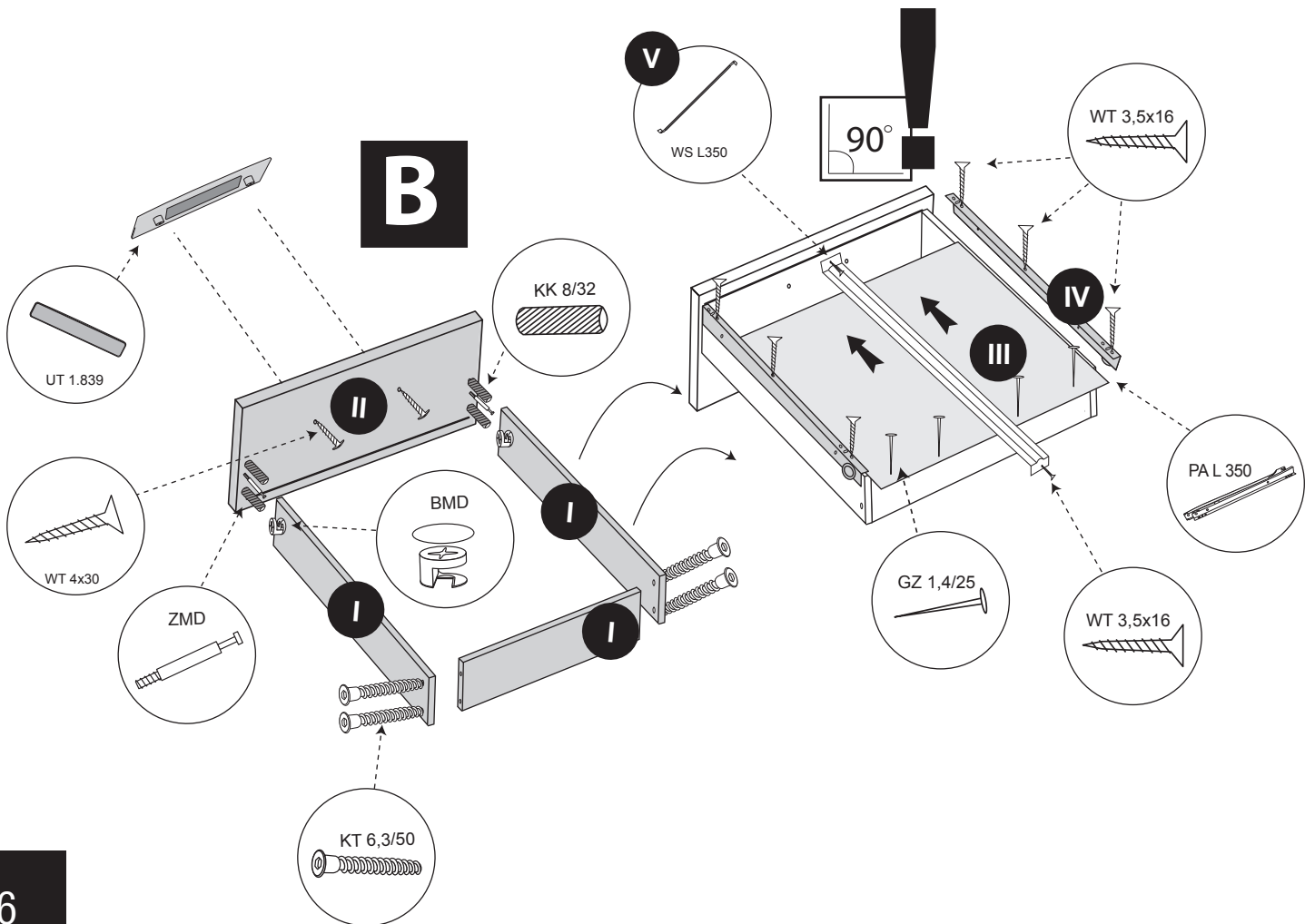
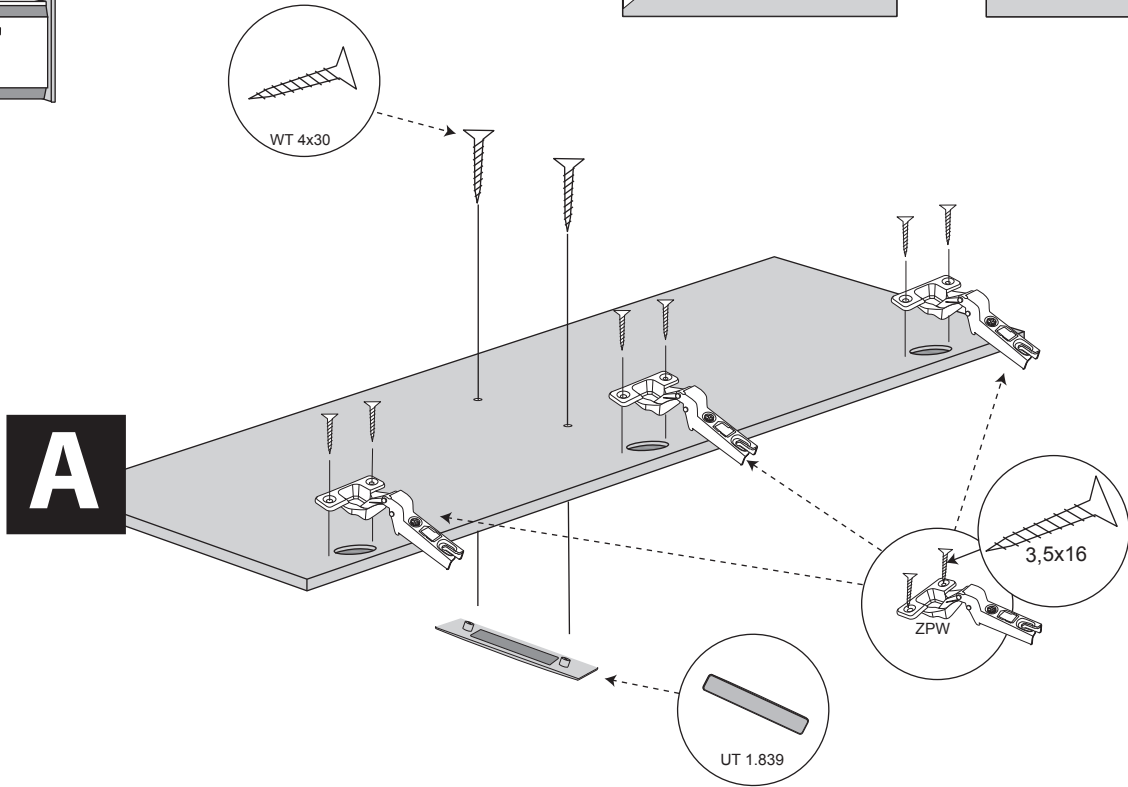
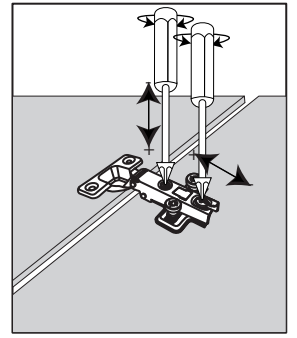
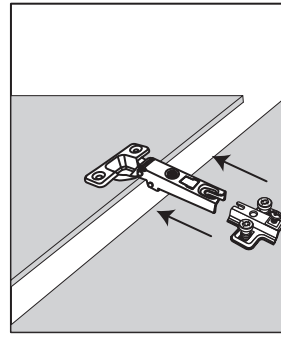
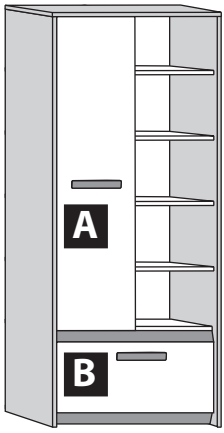



www.MLMEBLE.pl

GB D CZ SK RUS LT  
assembly instructions / montageanleitung / montážní návod / montážny návod / инструкции по монтажу / surinkimo instrukcija



## INSTRUKCJA MONTAŻU

**BEST 09**  
 94 90 41

akcesoria / accessories / zubehör / příslušenství / prislušenstvo / аксессуары / furnitūra :

x 30  KK 8/32	x 8  KT 6,3/50	x 60  GZ 1,4/25	x 4  SG 8/8	x 18  MD	x 6  ZAM	x 42  WT 3,5x16	x 6  WT 4x30	x 3  UT 1.839	x 1  PKZ	x 3  PAL 350
x 3  WS L 350	x 2  LT	x 1  kluczyk / key / schlüssel / klíč / ključ / ключ / raktas	x 1  klej / glue / kleber / lepidlo / lepidlo / kлей / kljaj							

do montażu potrzebne są:  
 are needed for assembly:  
 sind erforderlich für die montage:  
 jsou potřebné pro montáž:  
 sú potrebné pre montáž:  
 которые необходимы для сборки:  
 Surinkimui reikės:

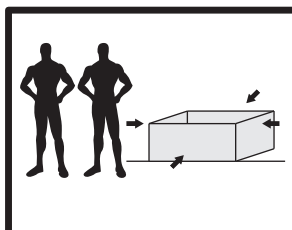
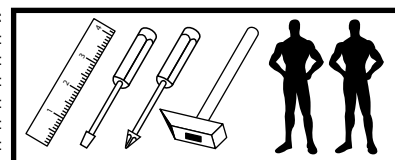

**UWAGA !** - mebel należy składać w pozycji poziomej  
**WARNING!** - furniture should be submitted in a horizontal position  
**WARNUNG!** - Möbel sollten in einer horizontalen Position vorzulegen  
**POZOR!** - Nábytek by měl být předložen ve vodorovné poloze  
**POZOR!** - Nábytok by mal byť predložený vo vodorovnej polohe  
**ВНИМАНИЕ!** - Мебель должна быть представлена в горизонтальном положении  
**DĚMESIO!** - Baldą surenkame horizontalioje padėtyje

**UWAGA !** - w pierwszej kolejności wbijamy akcesoria „KK” i „MD” w blaty oraz boki.  
**WARNING!** - The first accessory sticks "KK" and "MD" in the tops and sides.  
**WARNUNG!** - Die erste Accessoire-Sticks "KK" und "MD" in den Spitzen und an den Seiten.  
**POZOR!** - První příslušenství holí "KK" a "MD" v korunách a boky.  
**POZOR!** - Prvé príslušenstvo palíc "KK" a "MD" v korunách a boky.  
**ВНИМАНИЕ!** - Первый аксессуаров палочки "KK" и "MD" по верхинам и по бокам.  
**DĚMESIO!** - Pirmiausiai furnitūrą KK ir MD įkalame į stalviršį ir šonus.

Nr/No	Szt/Qty
1	1
2	1
3	1
4	2
5	3
6	1
7	8
8	1
9	2
10	4
11	2
12	3
13	3

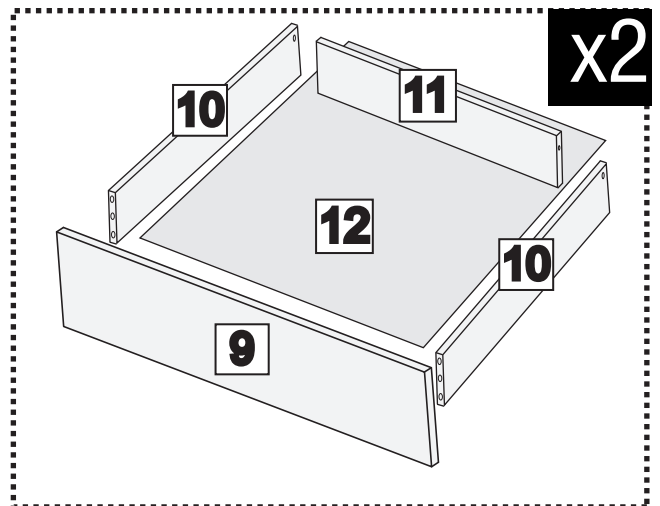
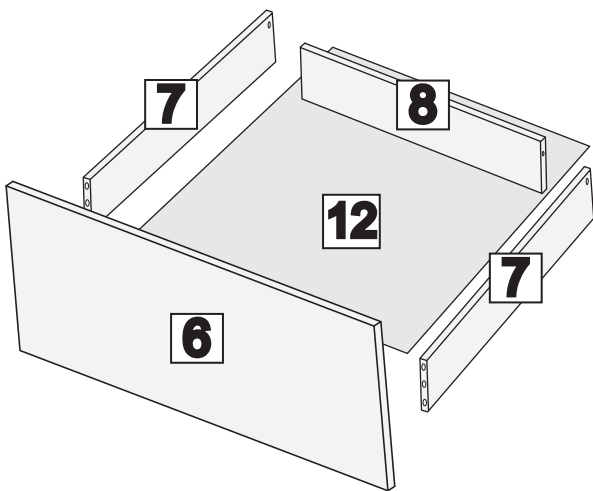
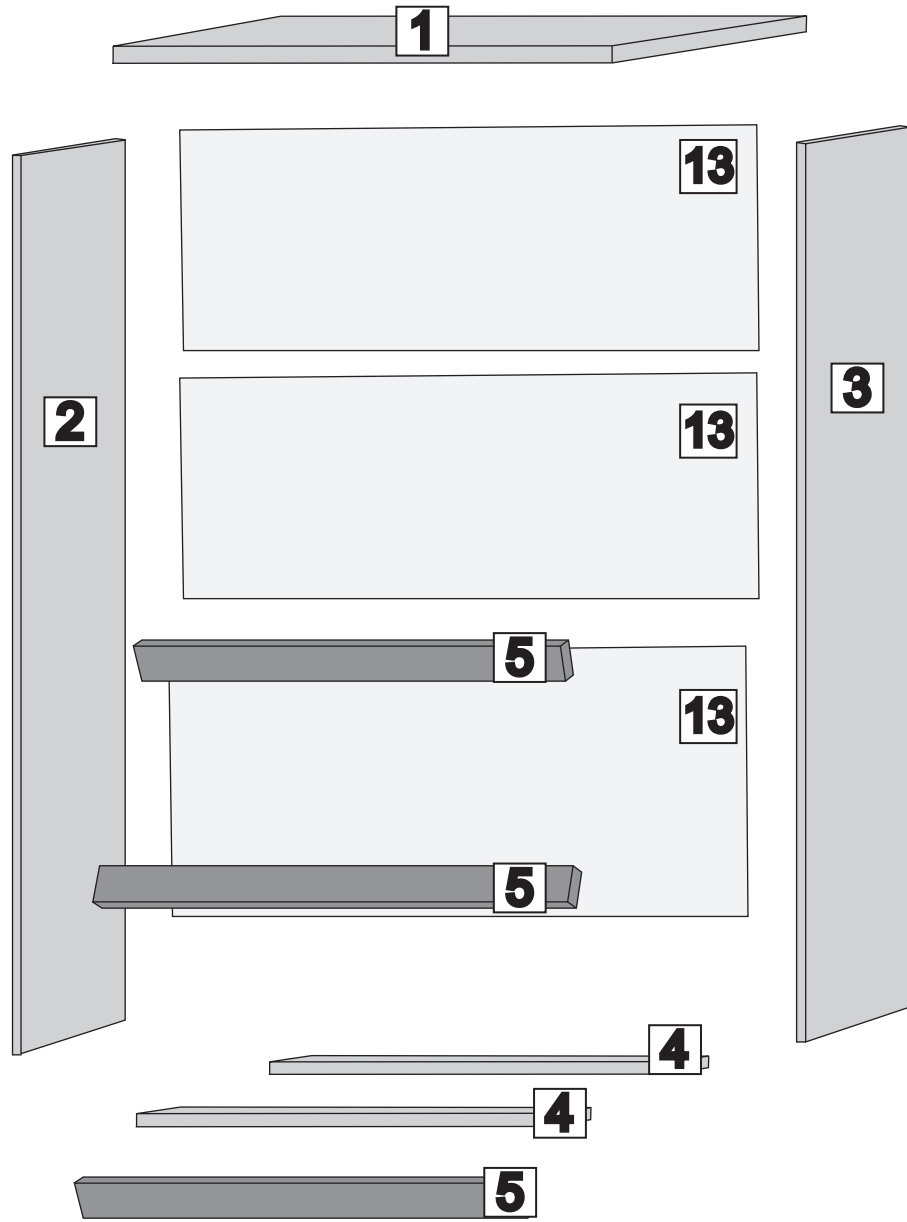



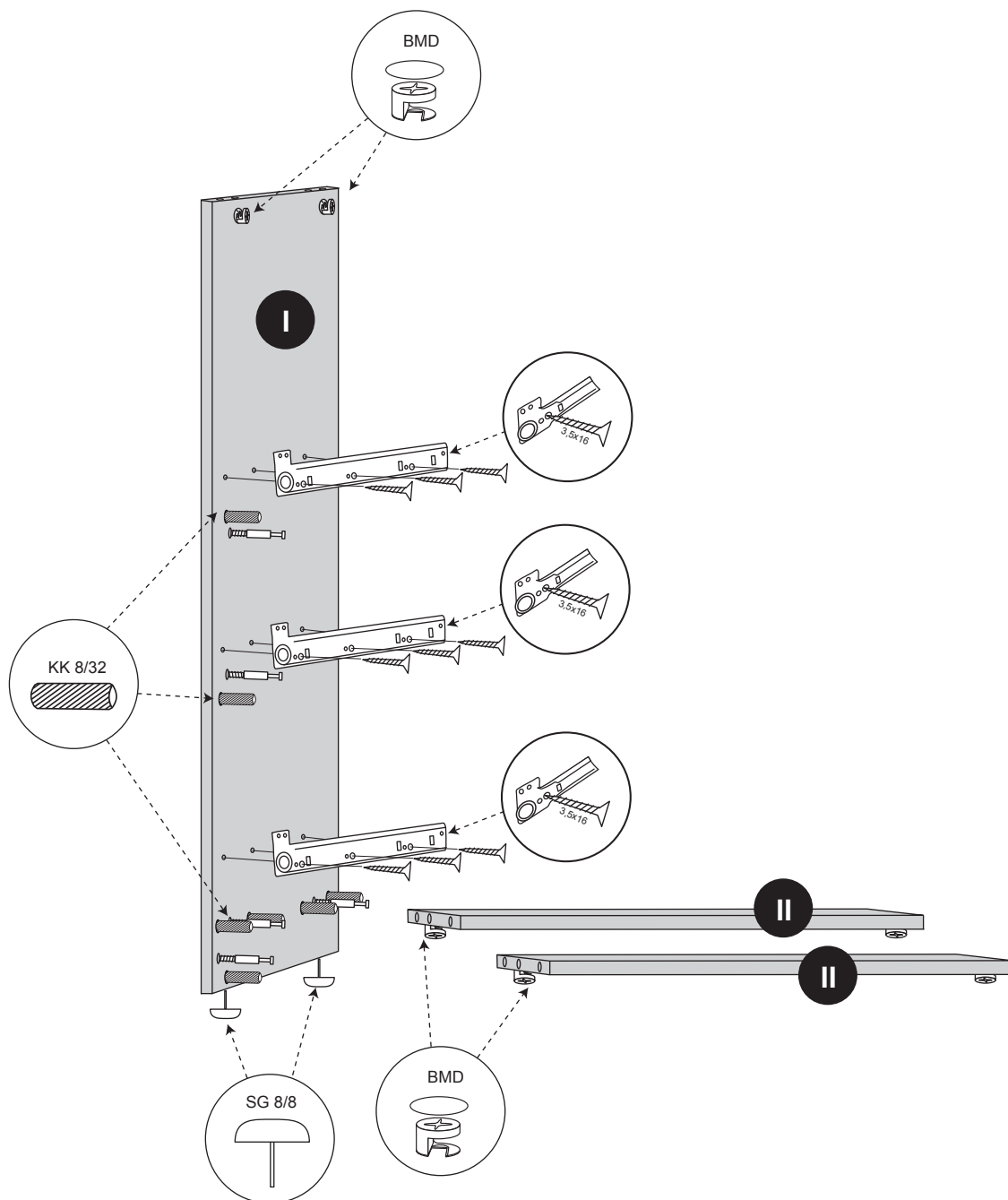
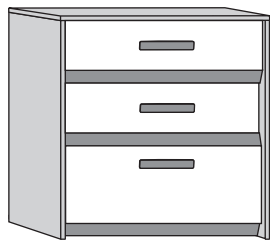

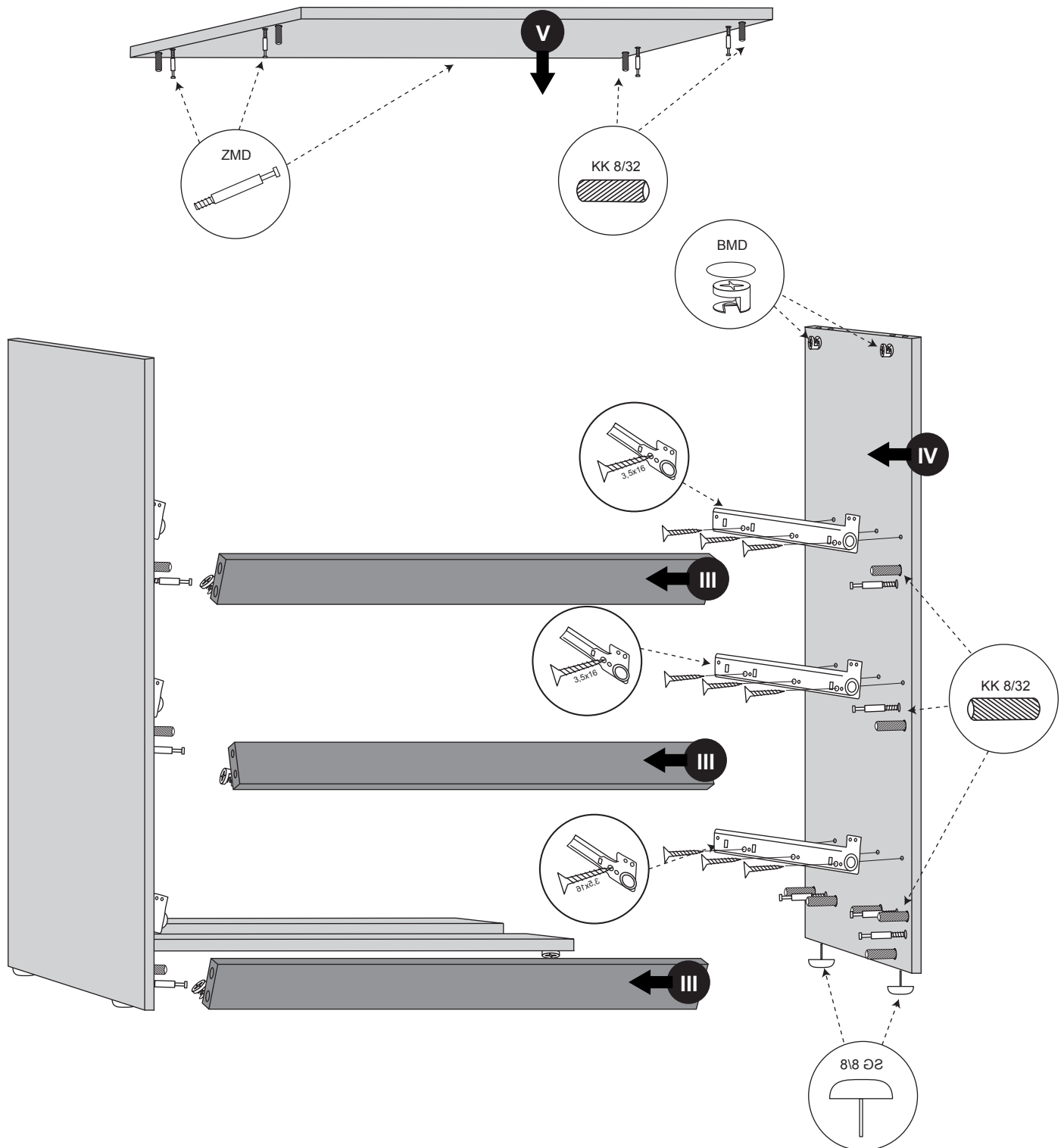
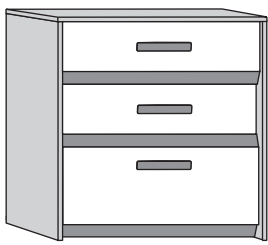

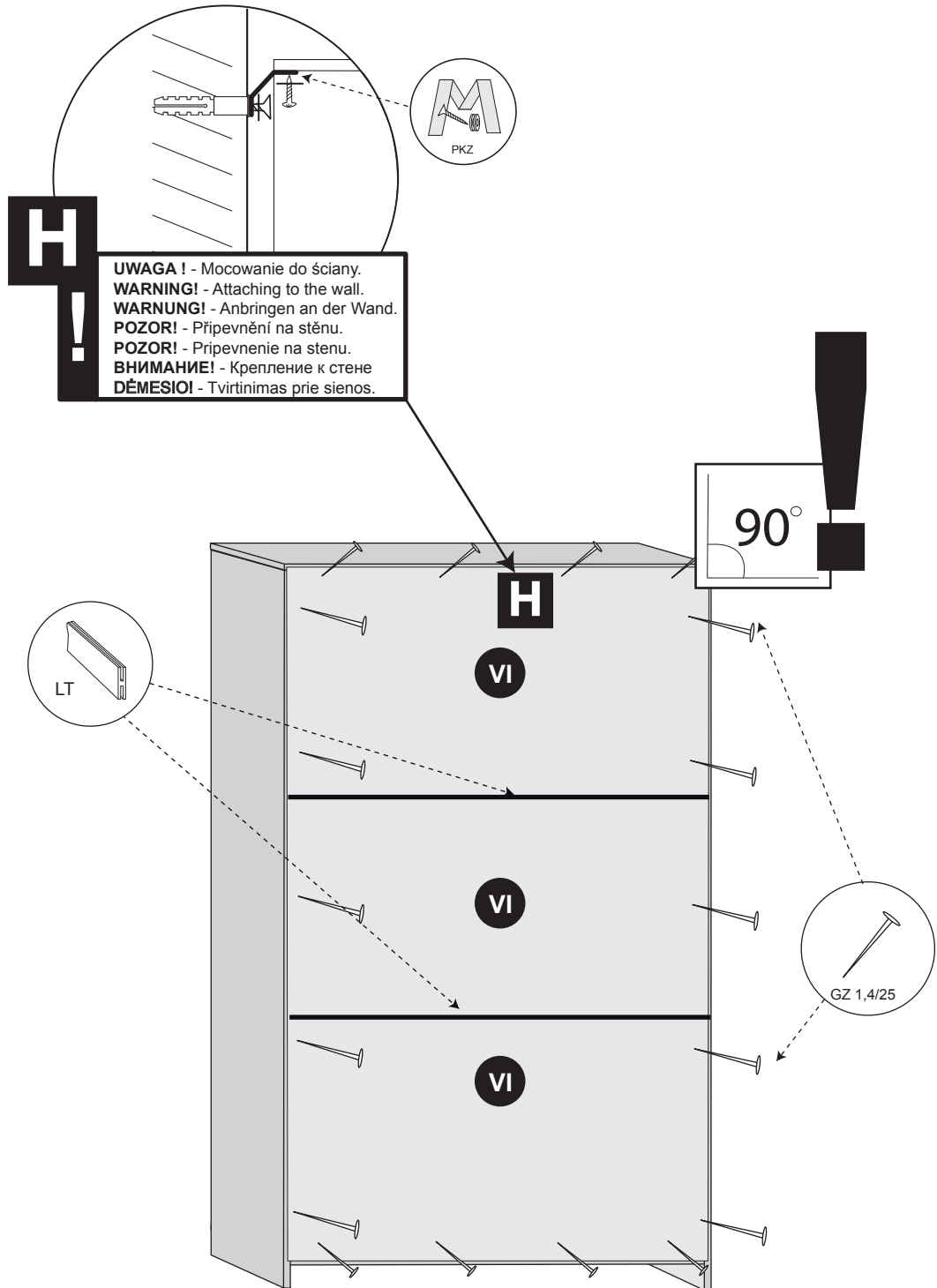
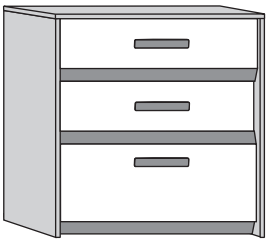

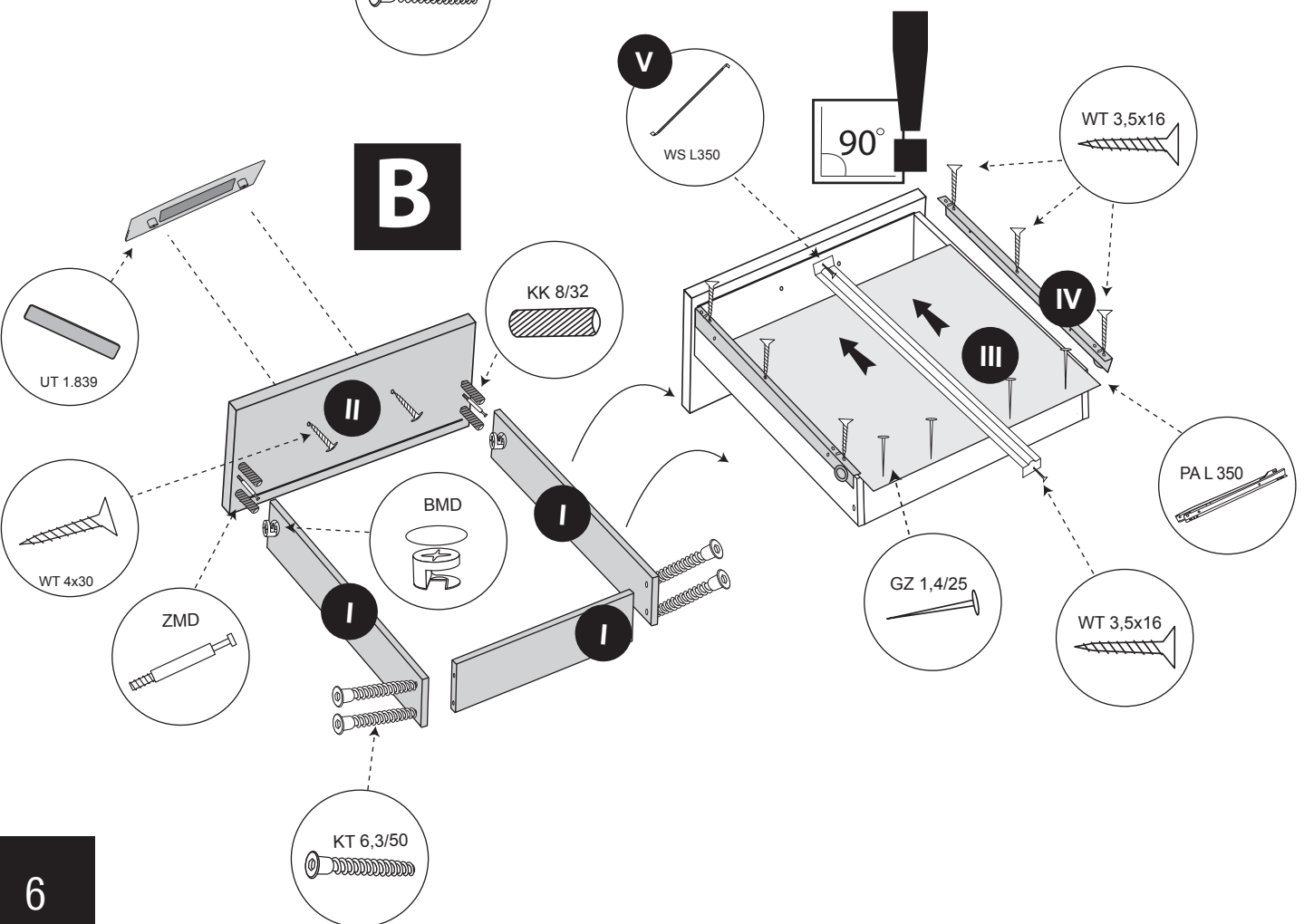
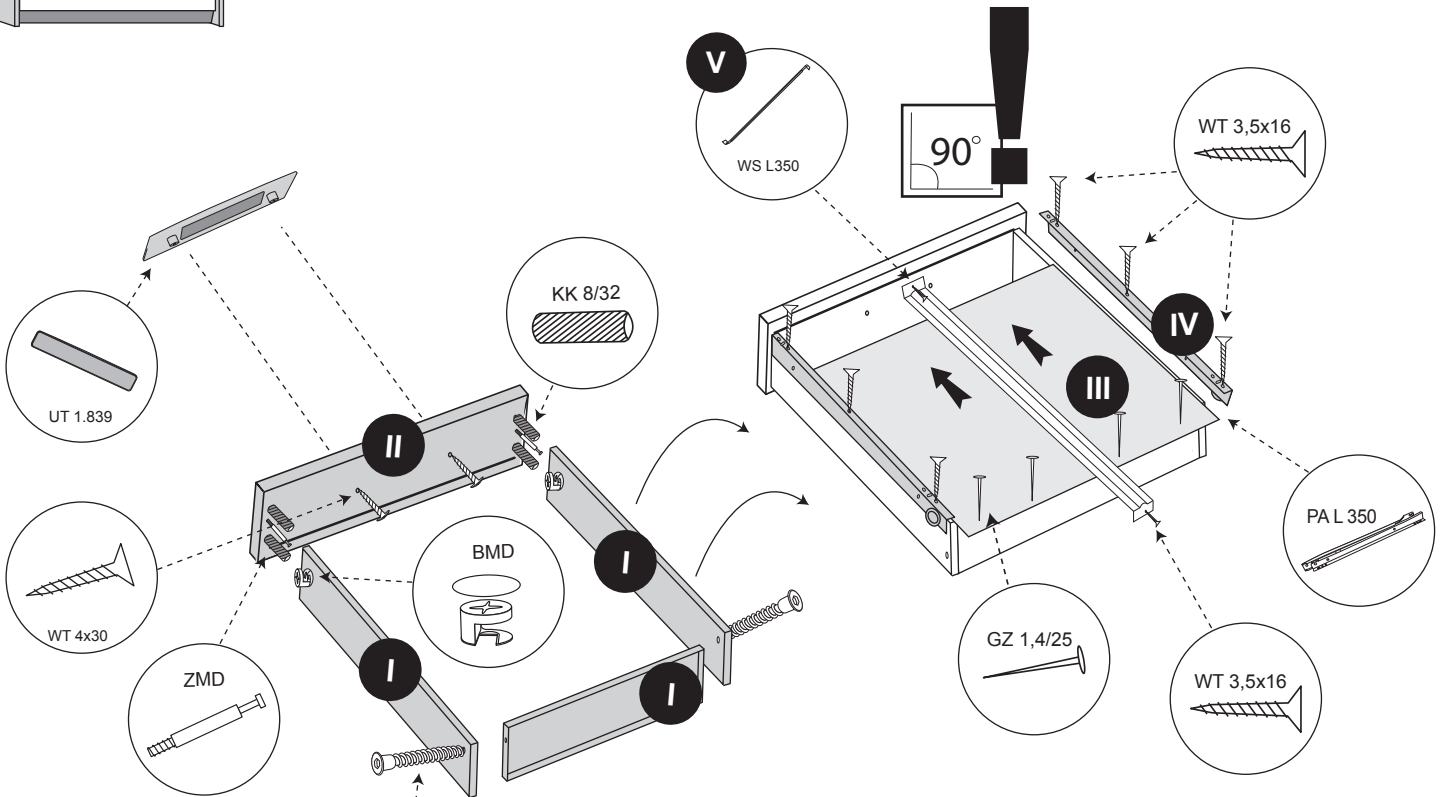
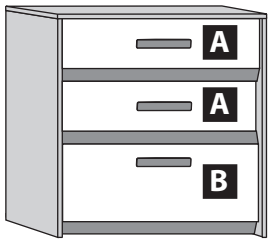

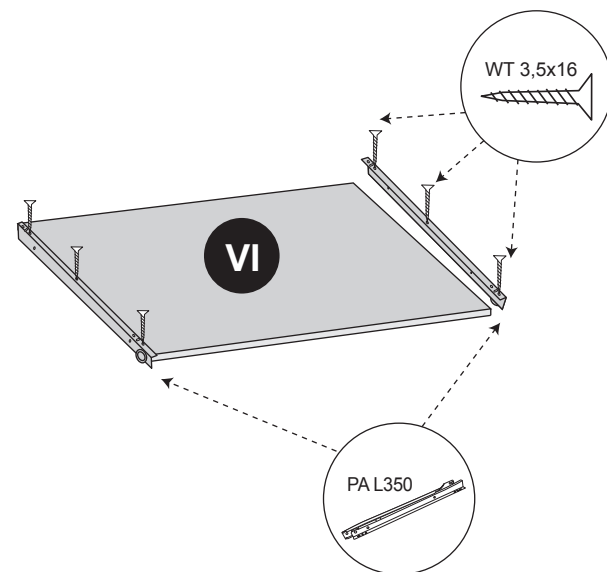
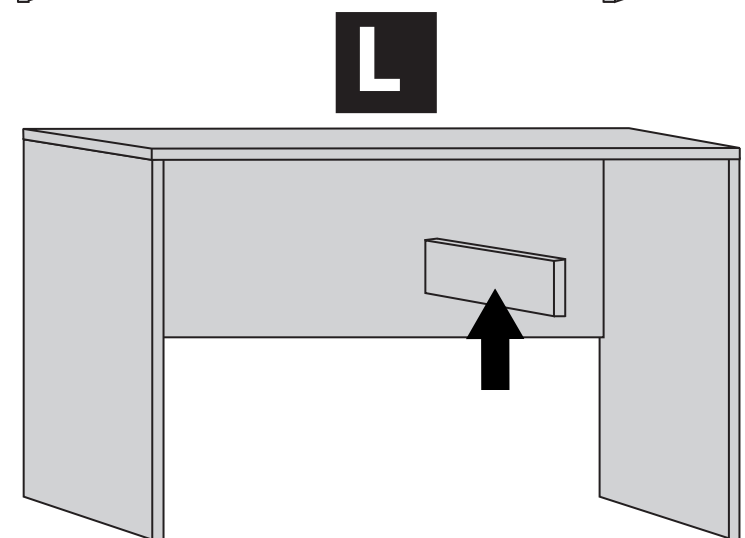
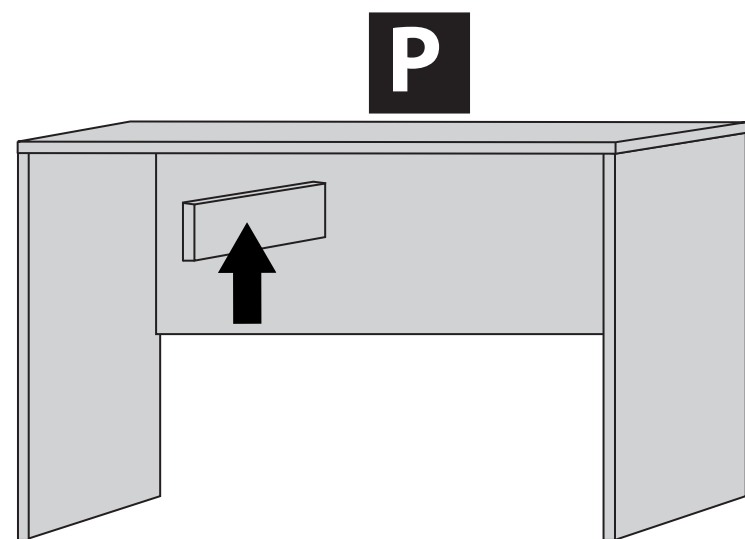
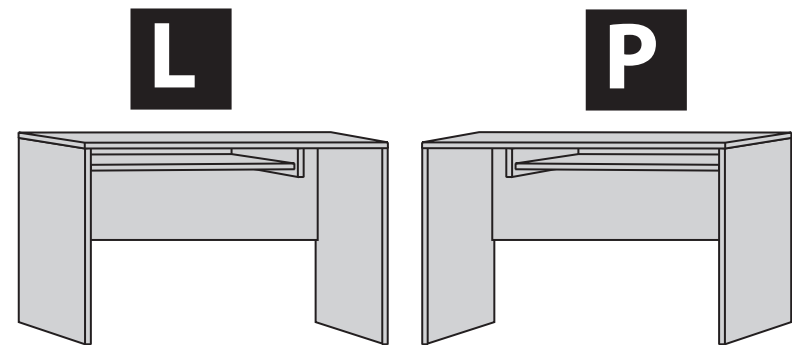

www.MLMEBLE.pl

GB D CZ SK RU LT  
assembly instructions / montageanleitung / montážní návod / montážny návod / инструкции по монтажу / surinkimo instrukcija



## INSTRUKCJA MONTAŻU

**BEST 12**  
↑76 →120 ↘55

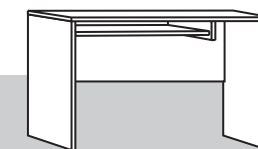

akcesoria / accessories / zubehör / příslušenství / prislušenstvo / аксессуары / furnitūra :

x 10 KK 8/32	x 1 KT 6,3/50	x 2 ZA N	x 10 MD	x 4 SG 8/8	x 12 WT 3,5x16	x 1 PA L350	x 1 kluczyk / key / schlüssel / klíč / kluč / kľov / raktas	x 1 klej / glue / kleber / lepidlo / lepidlo / klij / klijai
-----------------	------------------	-------------	------------	---------------	-------------------	----------------	--	---

**do montażu potrzebne są:**  
are needed for assembly:  
sind erforderlich für die montage:  
jsou potřebné pro montáž:  
sú potrebné pre montáž:  
которые необходимы для сборки:  
Surinkimui reikės:

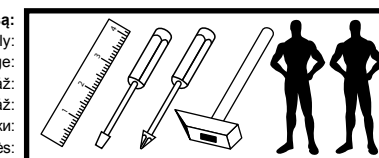

**! UWAGA!** - W pierwszej kolejności wbijamy akcesoria „KK” i „MD” w blaty oraz boki i montujemy prowadnice.  
**WARNING!** - In the first place should be driven accessories "KK" and "MD" in the tops and sides and guides.  
**WARNUNG!** - In erster Linie sollte Accessoires "KK" und "MD" in den Wipfeln und an den Seiten und Guides gefahren werden.  
**POZOR!** - V první řadě by měl být tažen příslušenství "KK" a "MD" v korunách a po stranách a průvodec.  
**POZOR!** - V prvom rade by mal byť ťahaný príslušenstvo "KK" a "MD" v korunách a po stranách a sprievodcov.  
**ВНИМАНИЕ!** - В первую очередь следует руководствоваться аксессуарами "KK" и "MD", на вершинах и по бокам и руководства.  
**DĖMESIO!** - Pirmiausiai furnitūrą KK ir MD įkalame į stalviršį ir šonus ir prisukame bėgelius.

Nr/No	Szt/Qty
1	1
2	1
3	1
4	1
5	1
6	1

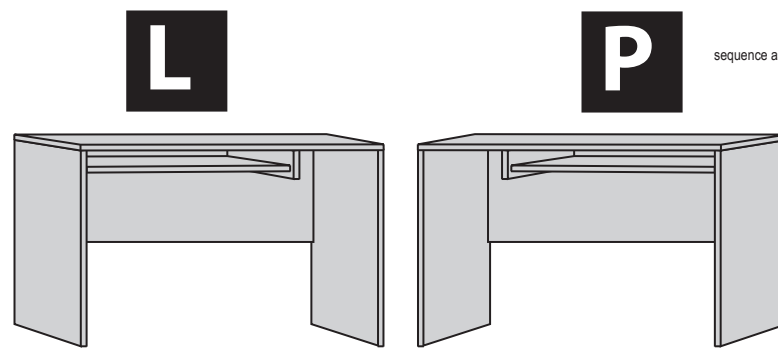
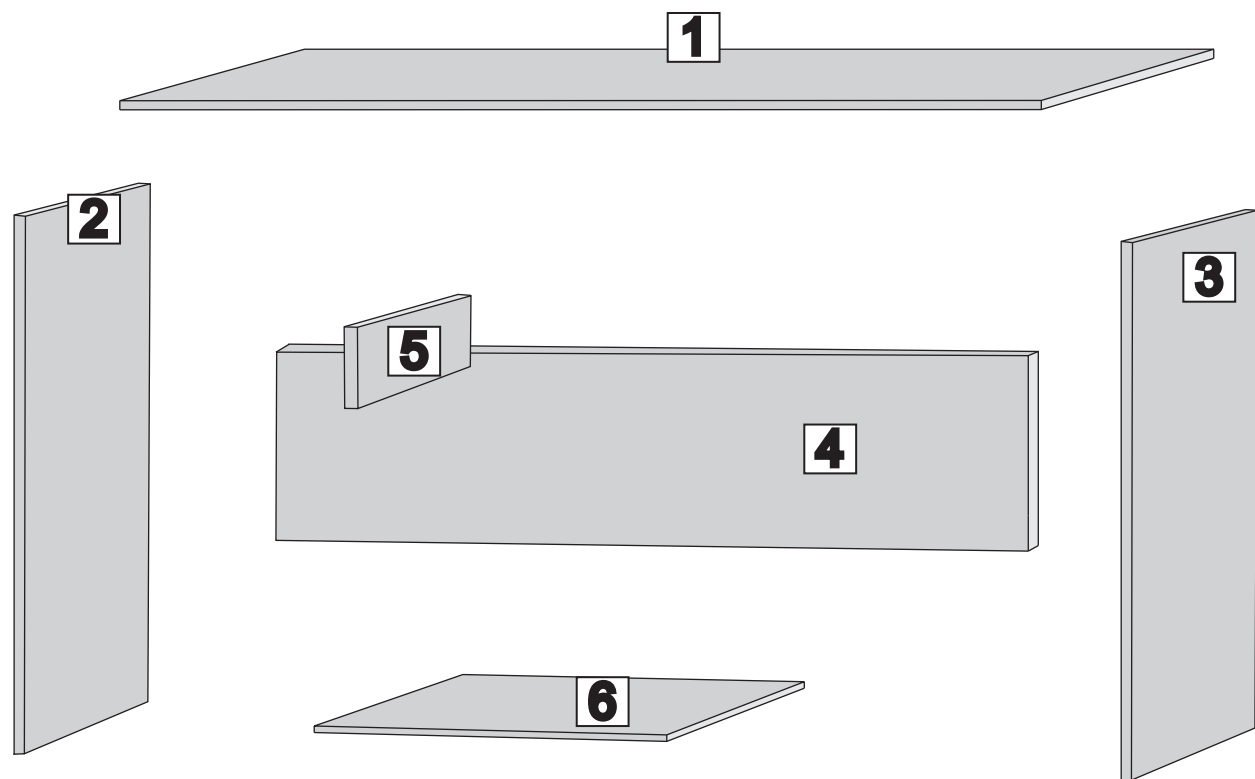

sequence assembly / reihenfolge montage / sekvence montáž / postupnosť montáže / последовательность сборки / surinkimo eiliškumas

Kolejność montażu: I II III IV V VI VII

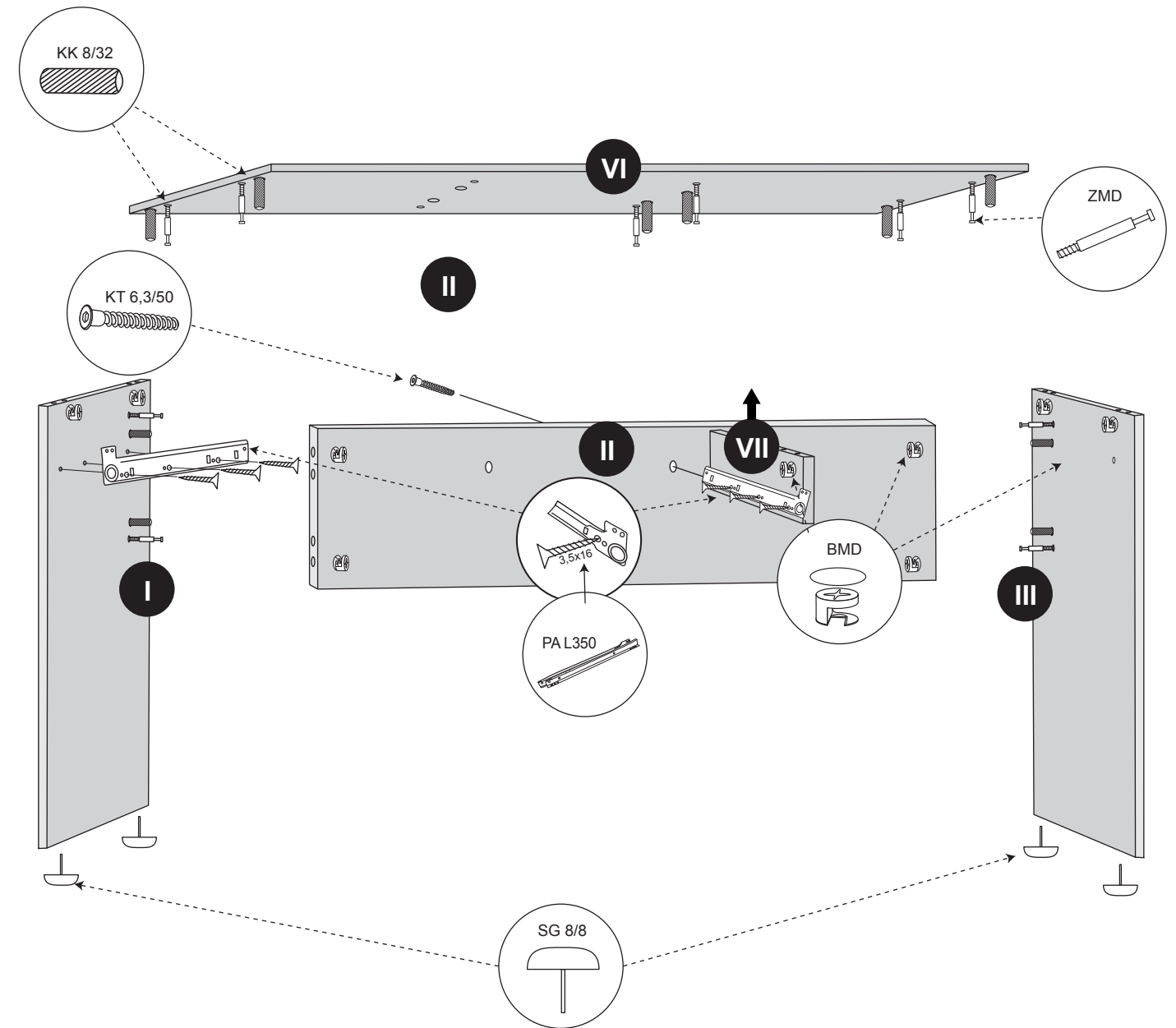

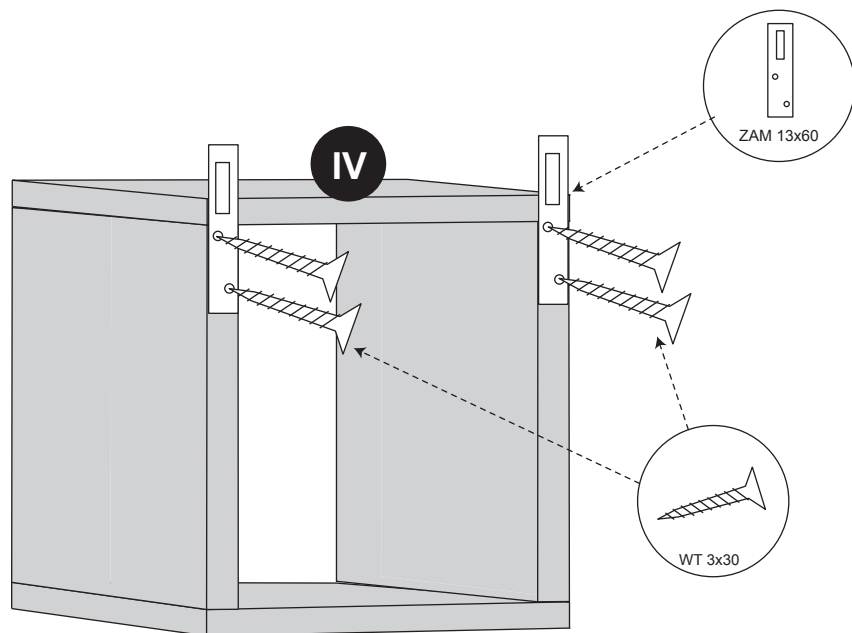

www.MLMEBLE.pl

GB D CZ SK RUS LT  
assembly instructions / montageanleitung / montážní návod / montážny návod / инструкции по монтажу / surinkimo instrukcija



## INSTRUKCJA MONTAŻU

**BEST 15**  
↑ 29 → 29 ↗ 20

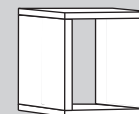

akcesoria / accessories / zubehör / příslušenství / prislušenstvo / аксессуары / furnitūra :

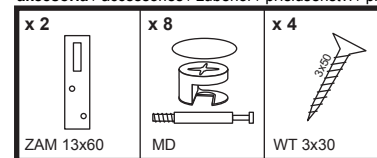

do montażu potrzebne są:  
are needed for assembly:  
sind erforderlich für die montage:  
jsou potřebné pro montáž:  
sú potrebné pre montáž:  
которые необходимы для сборки:  
Surinkimui reikės:

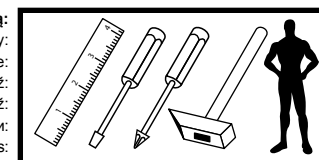

Nr/No	Szt/Qty
1	2
2	2

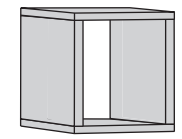
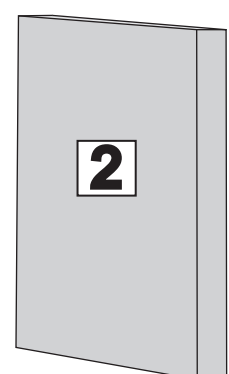
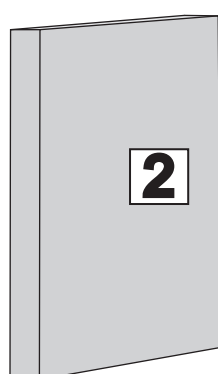
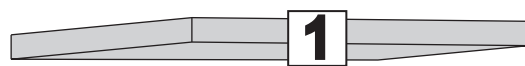

sequence assembly / reihenfolge montage / sekvence montáž / postupnost' montáže / последовательность ассамбли / surinkimo eiliškumas

Kolejność montażu: I II III IV

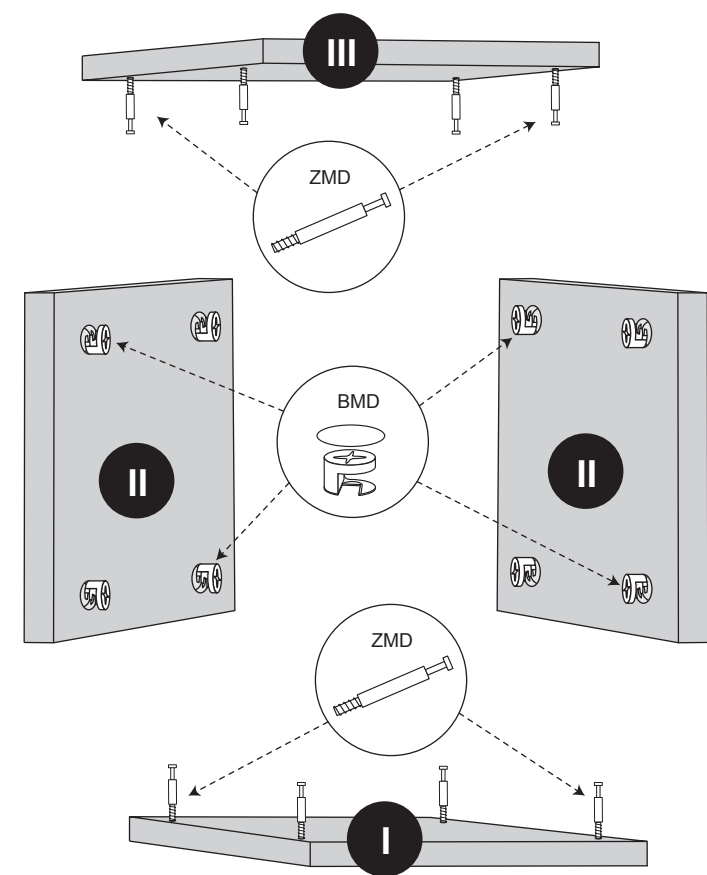





www.MLMEBLE.pl

GB D CZ SK RUS LT  
assembly instructions / montageanleitung / montážní návod / montážny návod / инструкции по монтажу / surinkimo instrukcija

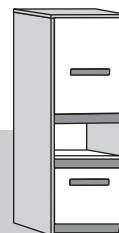

## INSTRUKCJA MONTAŻU

**BEST 16**  
↑140 →55 ↗41

akcesoria / accessories / zubehör / příslušenství / prislušenstvo / аксессуары / furnitūra :

x 26  KK 8/32	x 4  KT 6,3/50	x 50  GZ 1,4/25	x 4  SG 8/8	x 24  MD	x 6  ZAM	x 4  ZAM	x 4  PA Ø5	x 16  WT 3,5x16	x 4  WT 4x30	x 2  ZPW	
x 2  PK H-4	x 4  WE 6,3x13	x 1  PAL 350	x 1  PKZ	x 2  UT 1.839	x 1  LT	x 1  kluczyk / key / schlüssel / klíč / kľúč / ключ / raktas	x 1  klej / glue / kleber / lepidlo / lepidlo / клей / klijai				

do montażu potrzebne są:

are needed for assembly:

sind erforderlich für die montage:

jsou potřebné pro montáž:

sú potrebné pre montáž:

которые необходимы для сборки:

Surinkimui reikės:

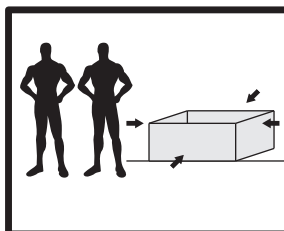
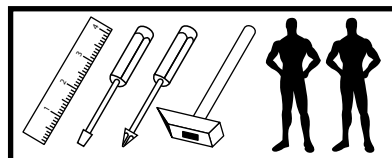

**UWAGA !** - mebel należy składać w pozycji poziomej

**WARNING!** - furniture should be submitted in a horizontal position

**WARNUNG!** - Möbel sollten in einer horizontalen Position vorzulegen

**POZOR!** - Nábytek by měl být předložen ve vodorovné poloze

**POZOR!** - Nábytok by mal byť predložený vo vodorovnej polohe

**ВНИМАНИЕ!** - Мебель должна быть представлена в горизонтальном положении

**DĚMESIO!** - Baldą surenkame horizontalioje padėtyje

**UWAGA !** - w pierwszej kolejności wbijamy akcesoria „KK” i „MD” w blaty oraz boki.

**WARNING!** - The first accessory sticks "KK" and "MD" in the tops and sides.

**WARNUNG!** - Die erste Accessoire-Sticks "KK" und "MD" in den Spitzen und an den Seiten.

**POZOR!** - První příslušenství holí "KK" a "MD" v korunách a boky.

**POZOR!** - Prvé príslušenstvo palíc "KK" a "MD" v korunách a boky.

**ВНИМАНИЕ!** - Первый аксессуаров палочки "KK" и "MD" по верхинам и по бокам.

**DĚMESIO!** - Pirmiausiai furnitūrą KK ir MD įkalame į stalviršį ir šonus.

Nr/No	Szt/Qty
1	1
2	1
3	1
4	1
5	1
6	1
7	2
8	3
9	1
10	1
11	2
12	1
13	1
14	2

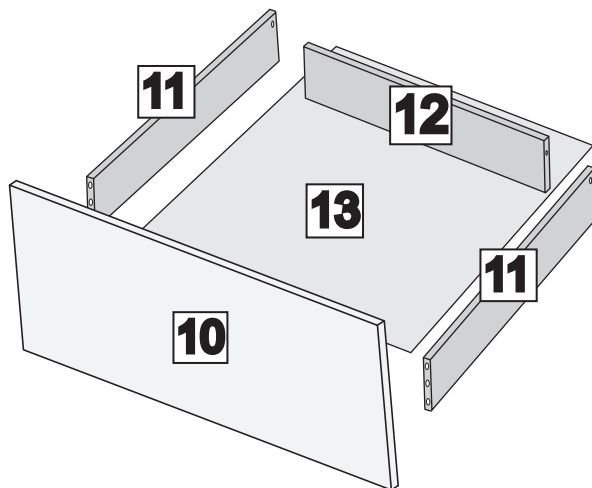
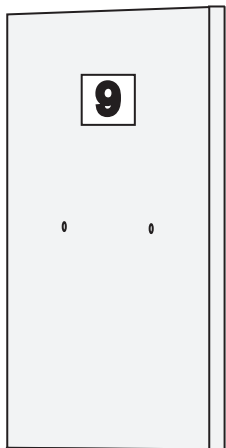
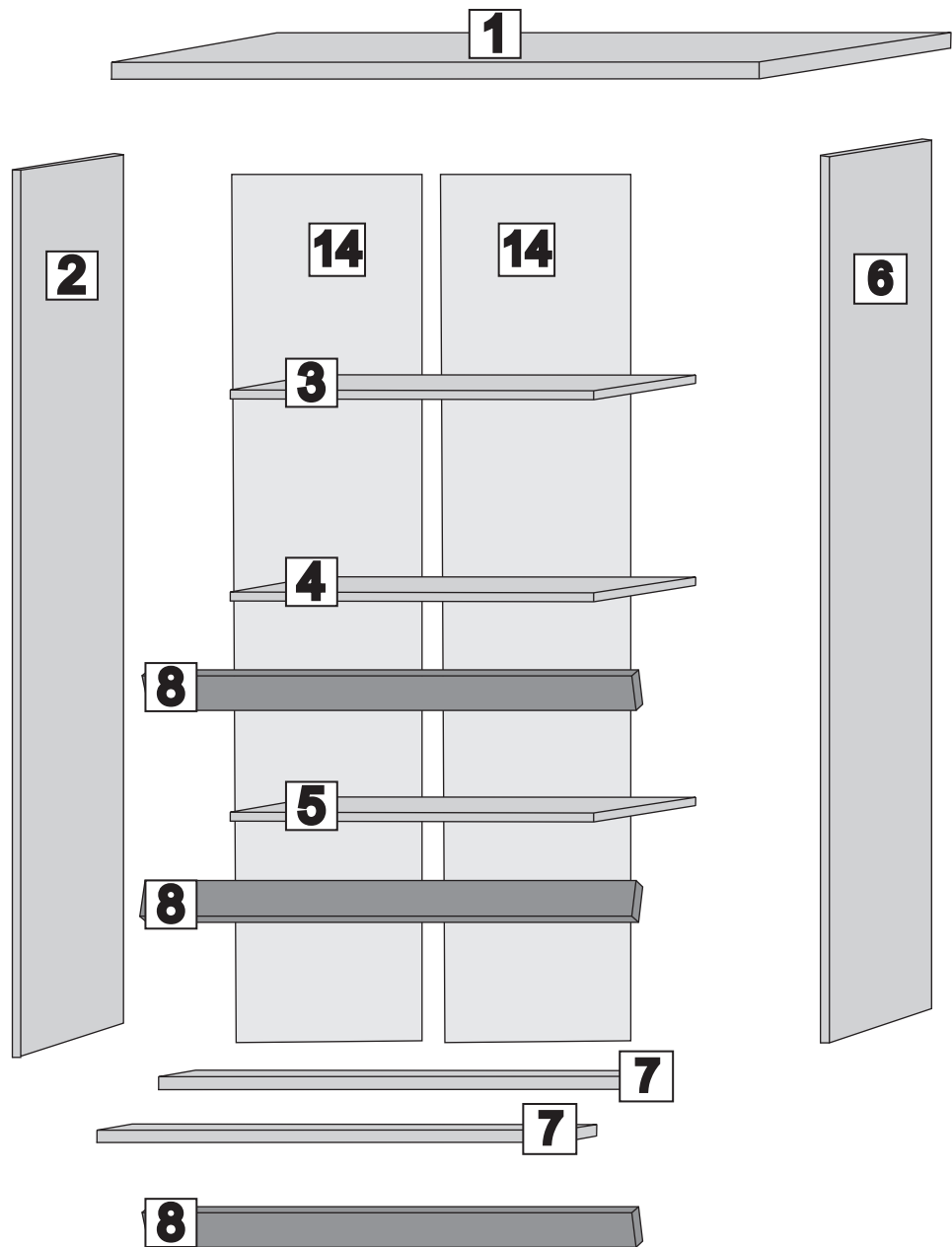

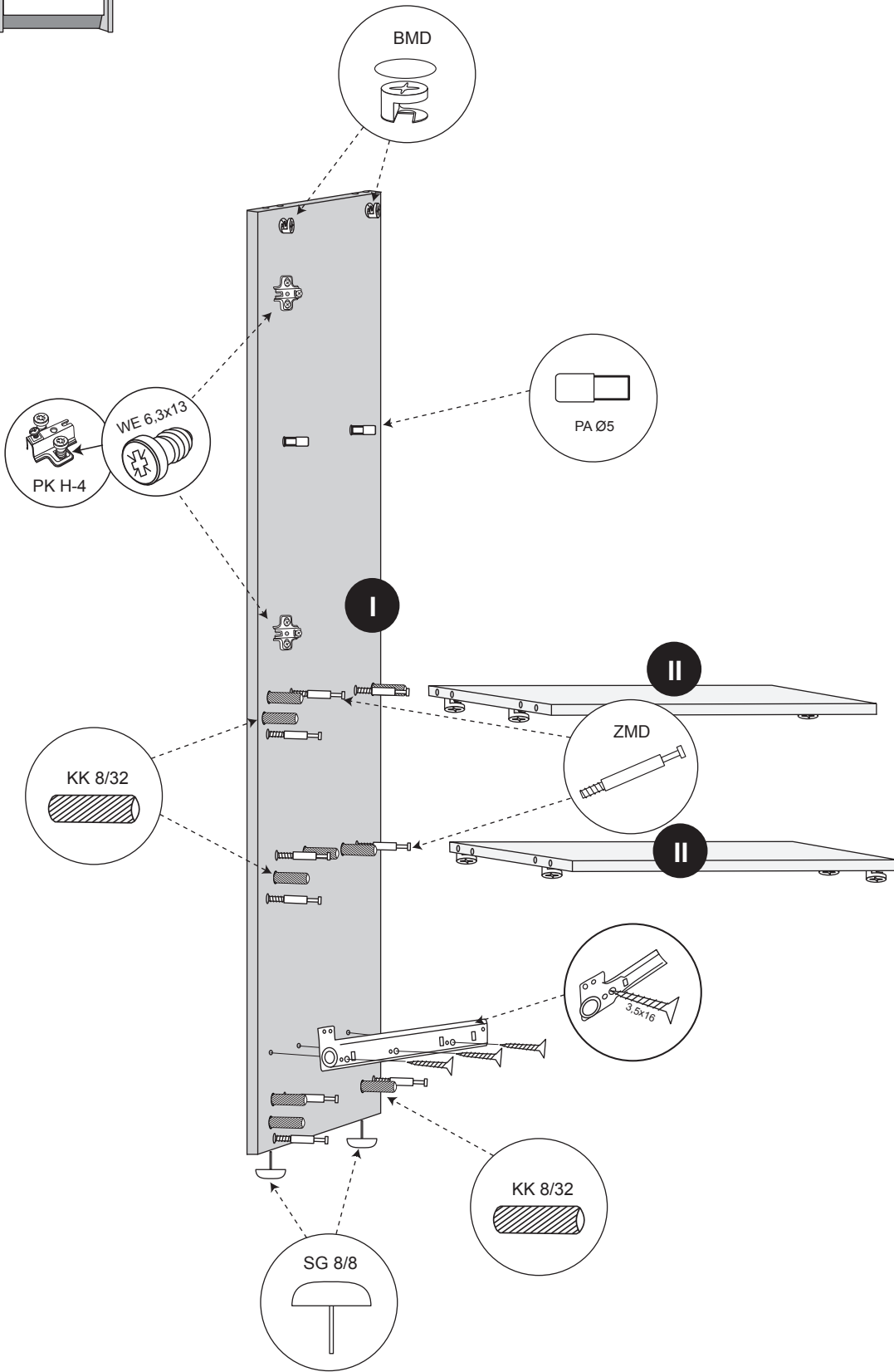
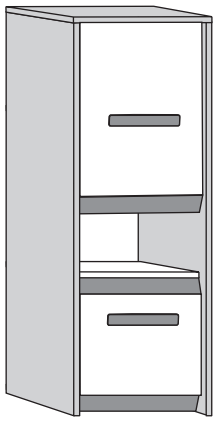

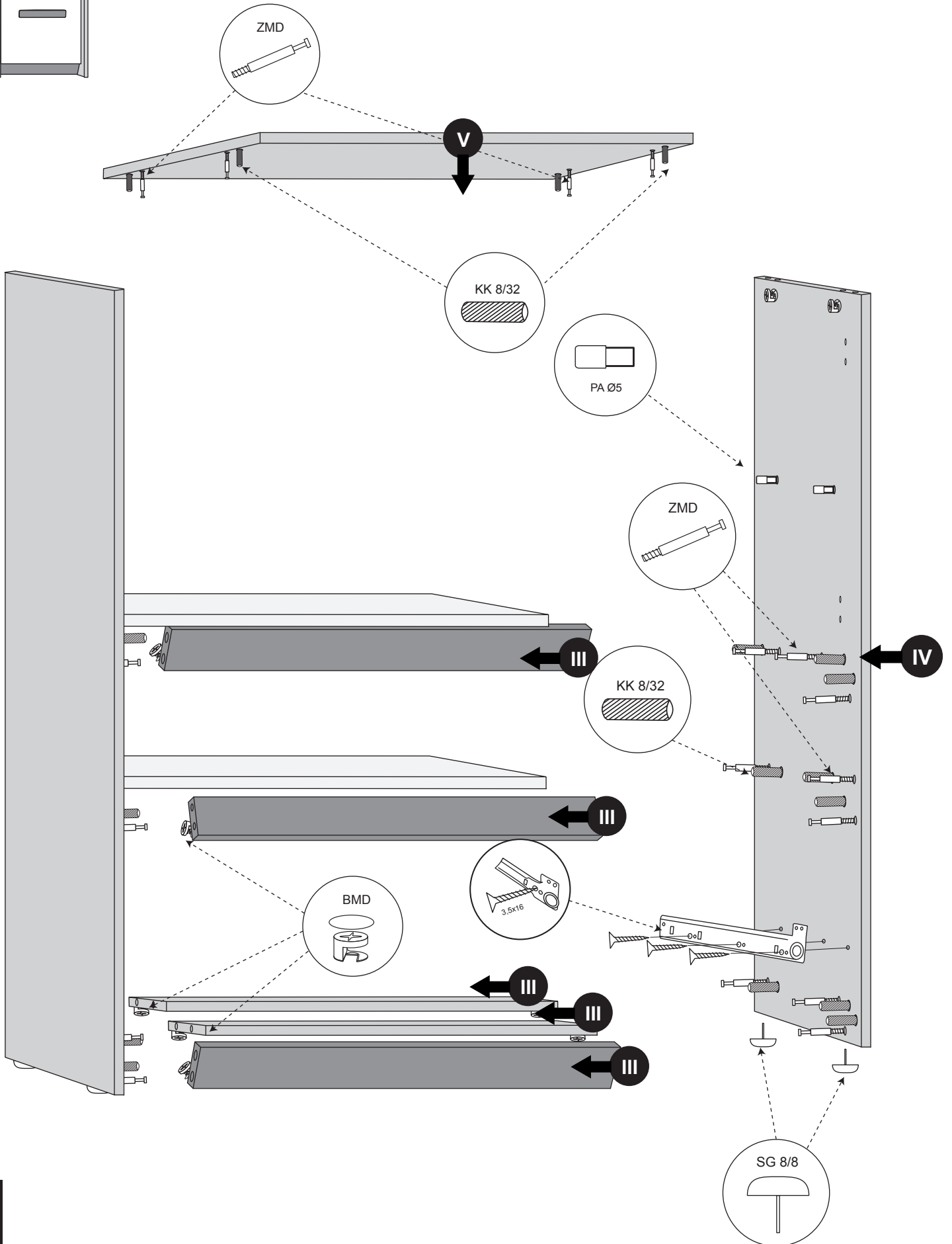
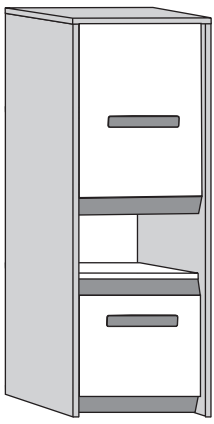

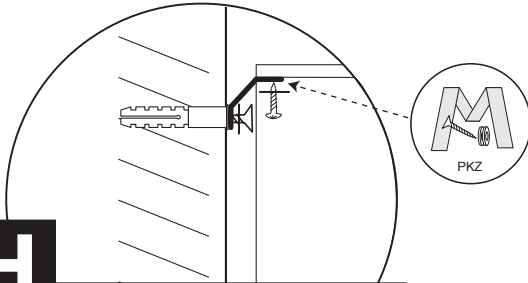
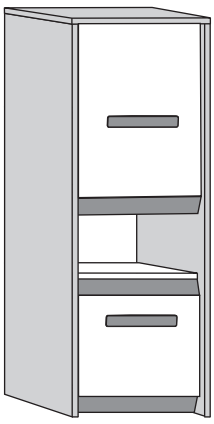

**H!**  
UWAGA! - Mocowanie do ściany.  
WARNING! - Attaching to the wall.  
WARNUNG! - Anbringen an der Wand.  
POZOR! - Připevnění na stěnu.  
POZOR! - Připevnenie na stenu.  
ВНИМАНИЕ! - Крепление к стене  
DĒMESIO! - Tvirtinimas prie sienos.

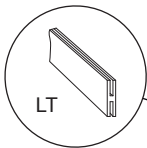
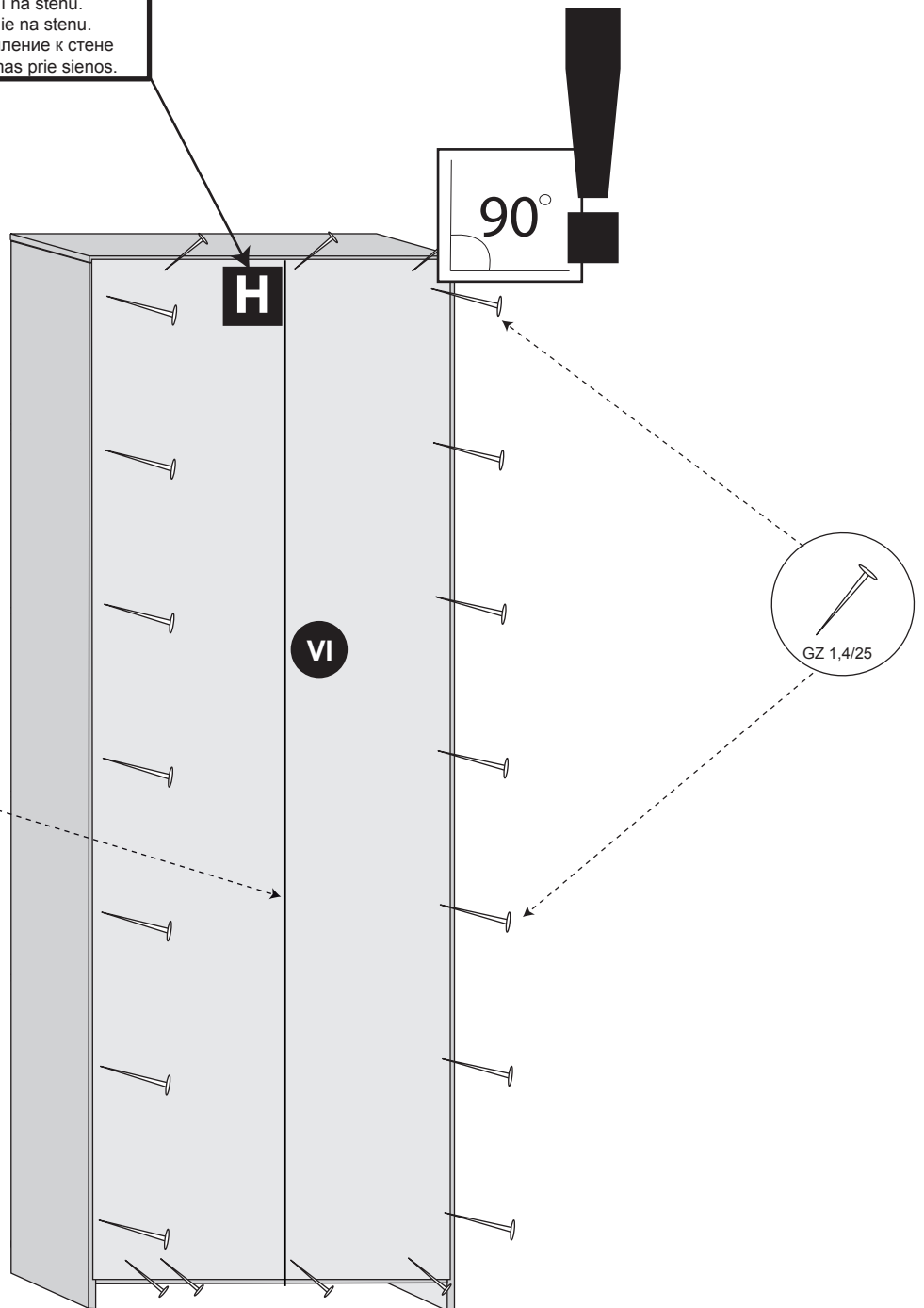

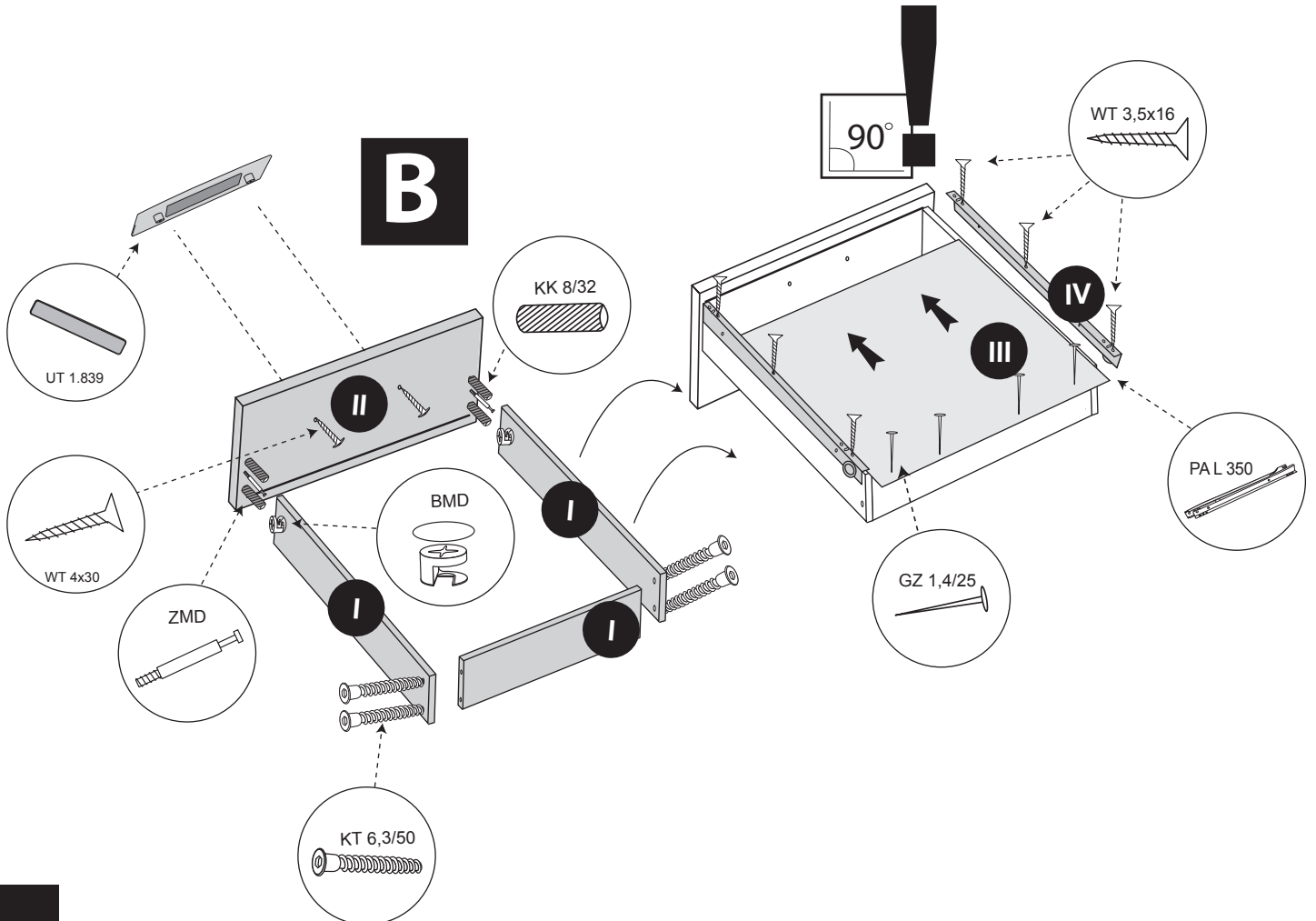
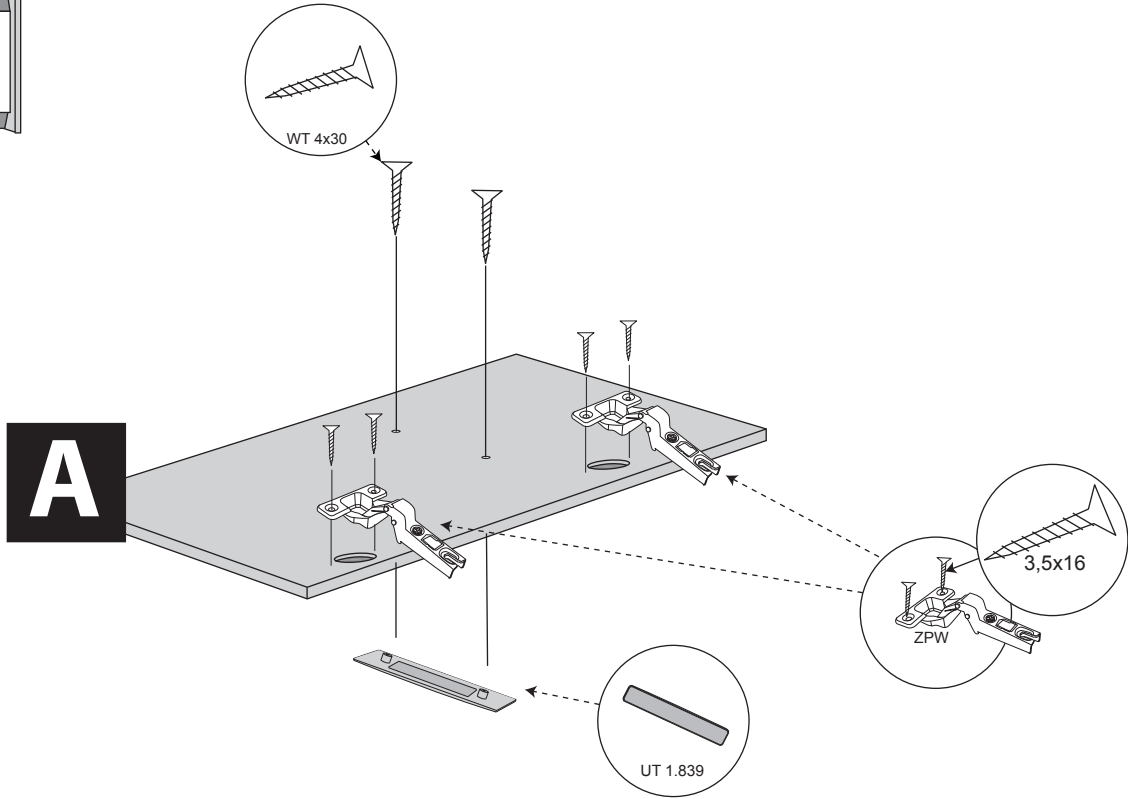
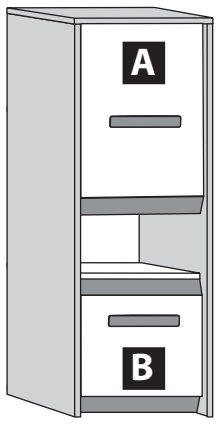



www.MLMEBLE.pl

GB D CZ SK RUS LT  
assembly instructions / montageanleitung / montážní návod / montážny návod / инструкции по монтажу / surinkimo instrukcija



# INSTRUKCJA MONTAŻU

**BEST 17**

↑69 →204 ↗94

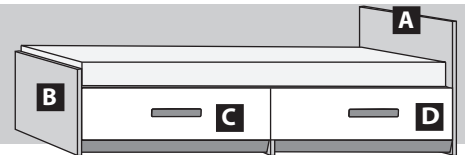

akcesoria / accessories / zubehör / příslušenství / prislušenstvo / аксессуары / furnitūra :

x 26  KK 8/32	x 10  KT 6,3/50	x 8  ZA N	x 6  SG 8/8	x 34  ZMD	x 42  BMD	x 8  ZAM	x 40  WT 3,5x16	x 62  WT 4x30	x 4  MD2 L76	x 4  KT 50
x 8  RP-33/G	x 8  RP-22	x 2  KT 75	x 1  kluczyk / key / schlüssel / klič / klúč / ключ / raktas	x 1  klej / glue / kleber / lepidlo / lepidlo / клеи / klijai						

**do montażu potrzebne są:**  
are needed for assembly:  
sind erforderlich für die montage:  
jsou potřebné pro montáž:  
sú potrebné pre montáž:  
которые необходимы для сборки:  
Surinkimui reikės:

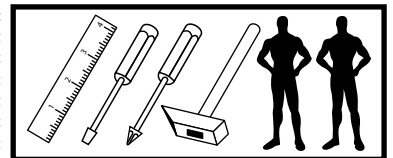

**! UWAGA !** - W pierwszej kolejności wbijamy akcesoria „KK” i „MD” w blaty oraz boki i montujemy prowadnice.  
**WARNING!** - In the first place should be driven accessories "KK" and "MD" in the tops and sides and guides.  
**WARNUNG!** - In erster Linie sollte Accessoires "KK" und "MD" in den Wipfeln und an den Seiten und Guides gefahren werden.  
**POZOR!** - V první řadě by měl být tažen příslušenství "KK" a "MD" v korunách a po stranách a průvodiců.  
**POZOR!** - V prvom rade by mal byť ťahaný príslušenstvo "KK" a "MD" v korunách a po stranách a sprievodcov.  
**ВНИМАНИЕ!** - В первую очередь следует руководствоваться аксессуарами "KK" и "MD", на вершинах и по бокам и руководства.  
**DĚMESIO!** - Pirmiausiai furnitūrą KK ir MD įkalame į stalviršį ir šonus ir prisukame bėgelius.

Nr/No	Szt./Qty
1	2
2	2
3	1
4	1
5	2
6	2
7	2
8	1
9	2
10	2
11	2
12	1
13	1
14	2
15	2

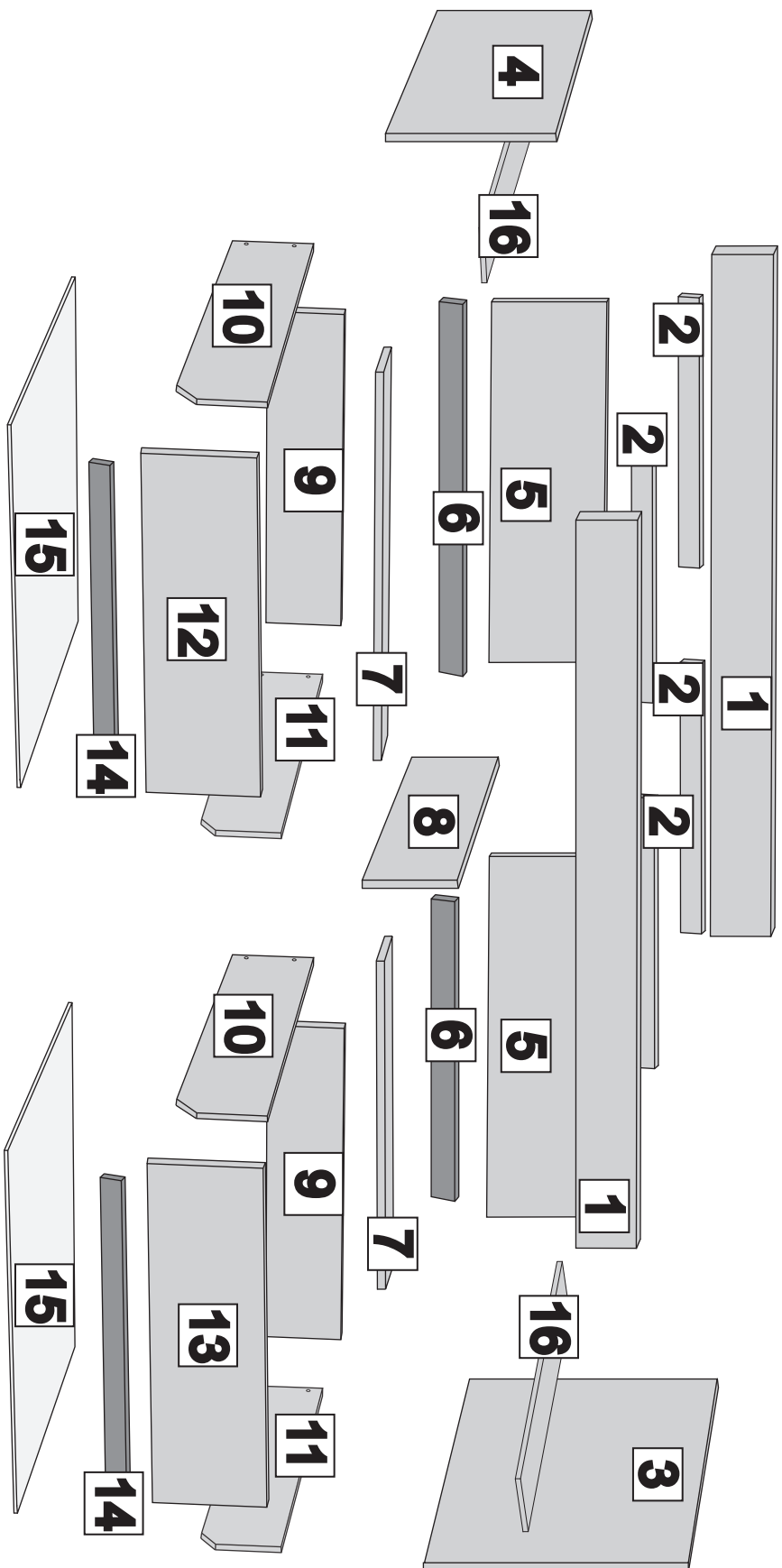



Possibility of assembling the right-left.  
 Möglichkeit der Montage der rechts-links.  
 Možnost montáže vpravo-vlevo.  
 Возможность монтажа вправо-влево  
 Galima padaryti pusę kairę arba dešinę.



sequence assembly / reihenfolge montage / sekvence montáž / postupnosť montáže / последовательность ассамблеи / surinkimo eiliškumas

Kolejność montażu: I II III IV V VI VII VIII IX

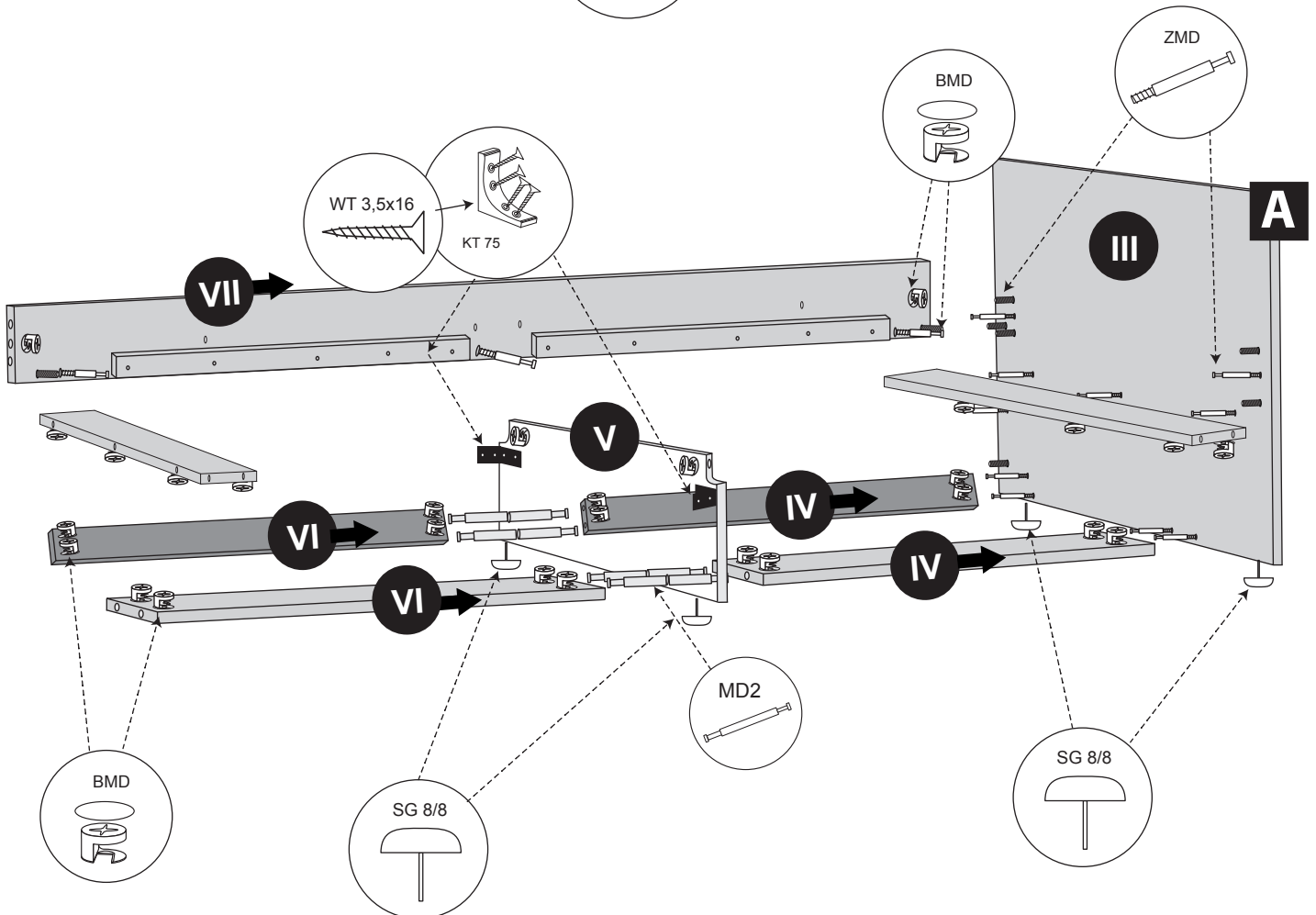
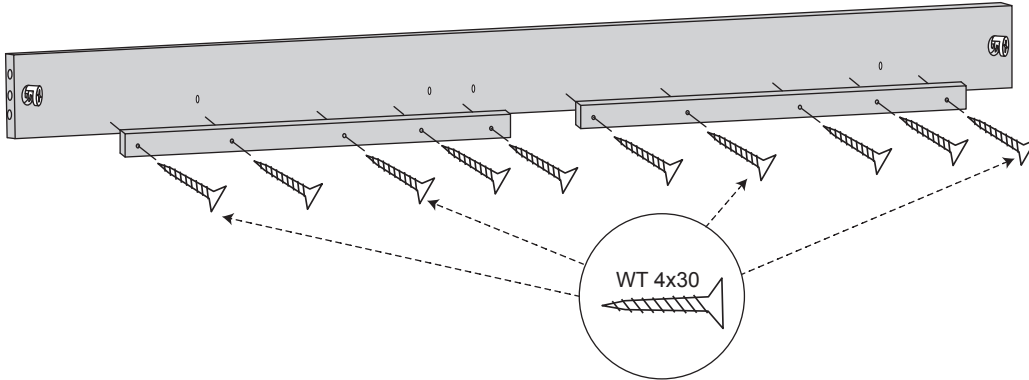
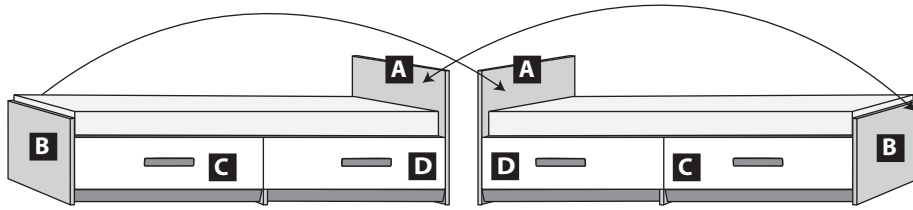

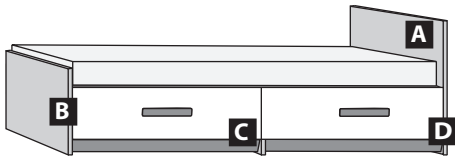

sequence assembly / reihenfolge montage / sekvence montáž / postupnosť montáže / последовательность ассамблеи / surinkimo eiliškumas

Kolejność montażu: I II III IV V VI VII VIII IX

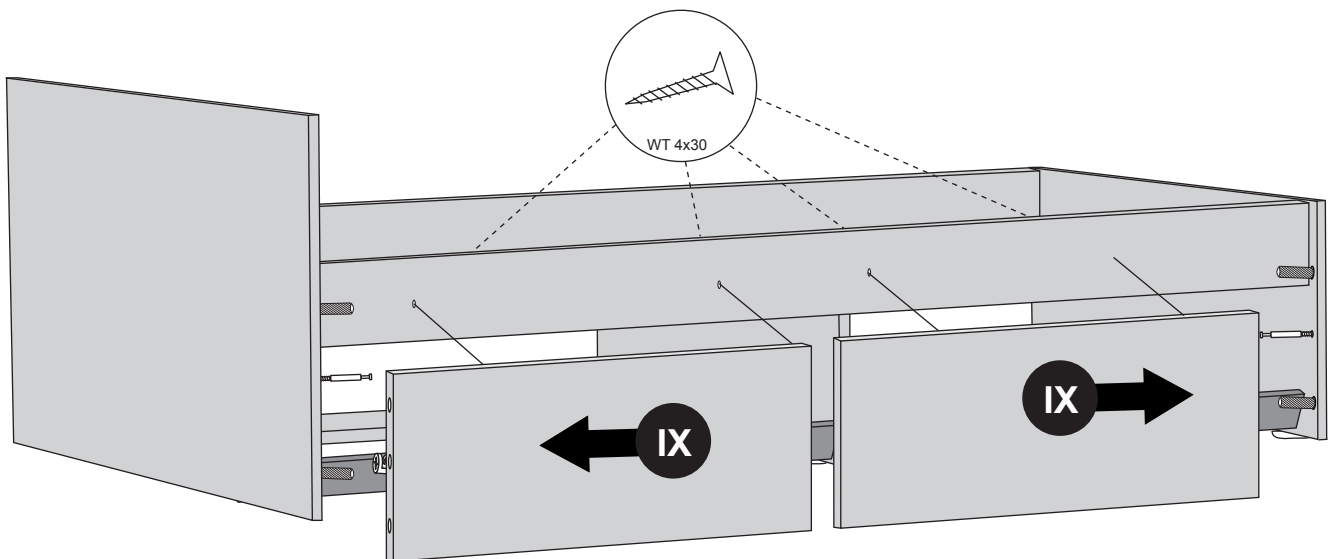
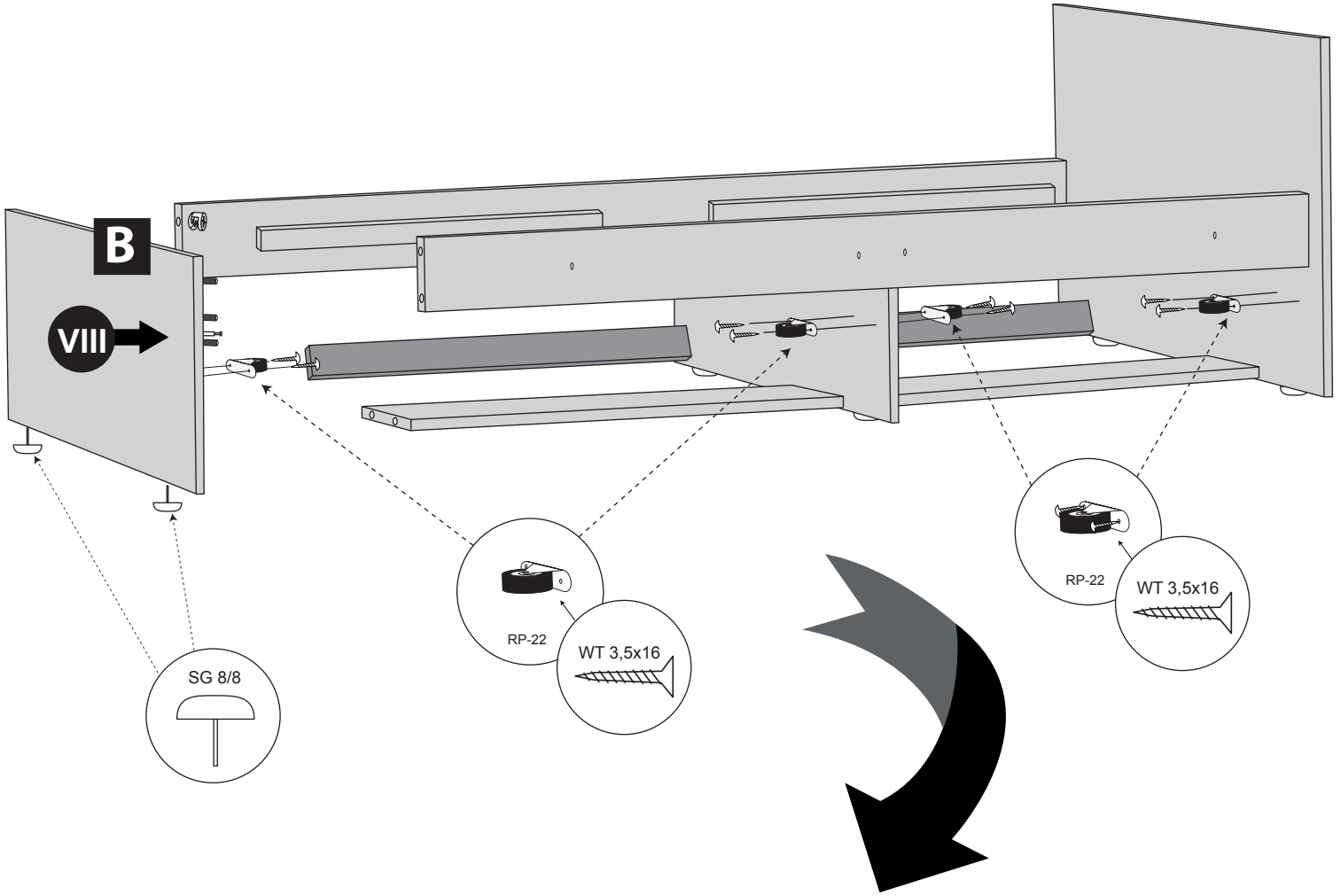

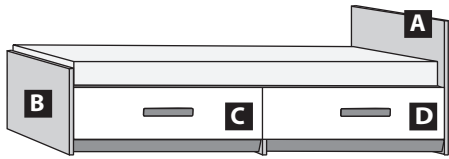

x2

