

Do montażu potrzebne są:
 Für die Montage dieser Type benötigen Sie:

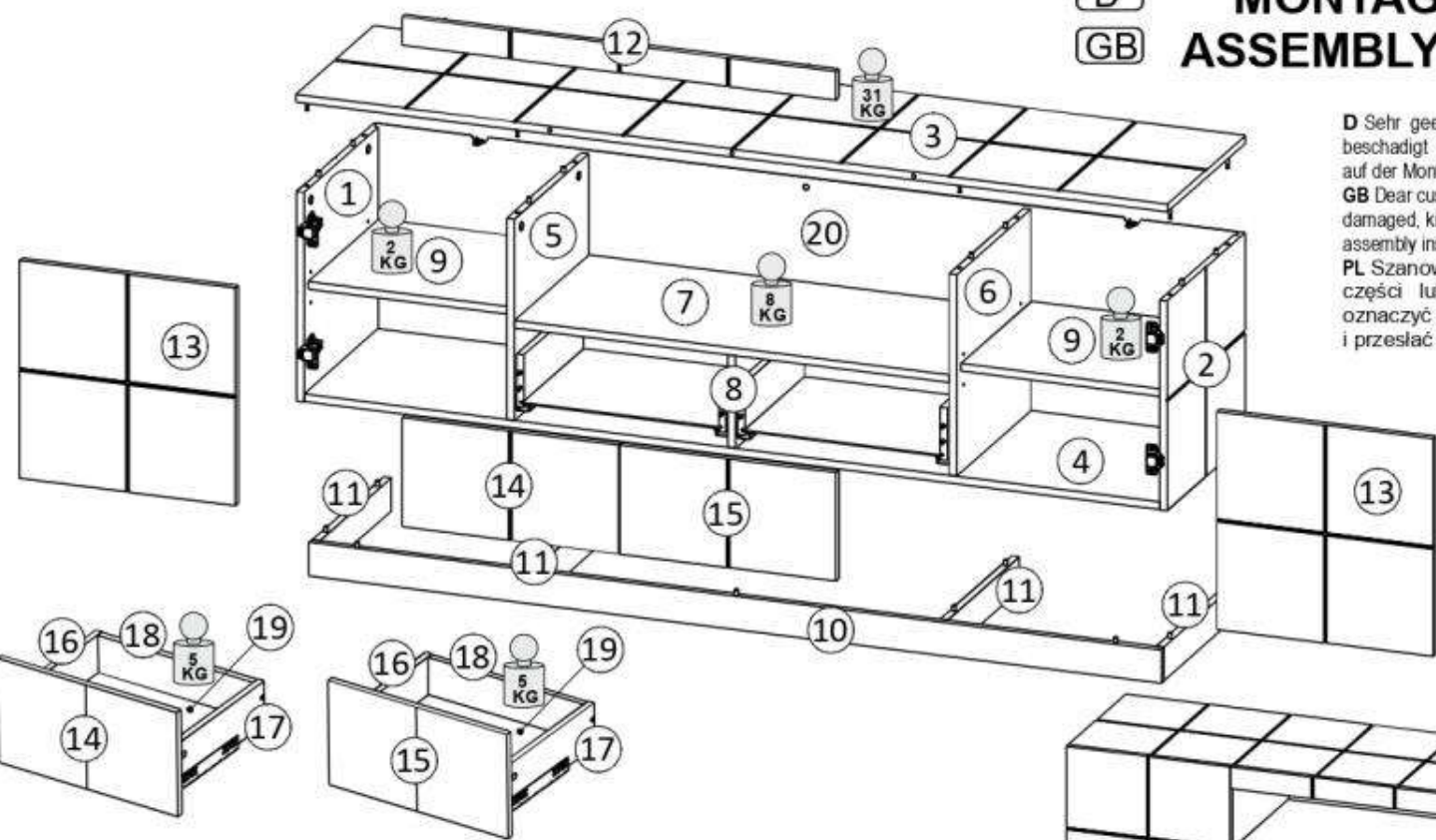
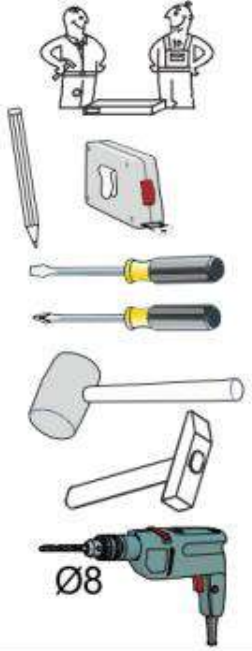

D Sehr geehrter Kunde, sollte ein Teil fehlen oder beschädigt sein, kreuzen Sie bitte dieses deutlich auf der Montageanleitung an und schicken Sie zu uns ab.
GB Dear customer, Should there be any place missing or damaged, kindly mark this place clearly on the attached assembly instructions and return it to us.
PL Szanowny Kliencie, gdyby brakowało jakiejś części lub byłaby uszkodzona proszę to oznaczyć krzyżykiem na instrukcji montażowej i przesłać instrukcję razem z reklamacją.

Pflegehinweis!
 Bitte nur mit einem Staubtuch oder einem fauchtem Lappen reinigen. KEINE scheuernde Putzmittel verwenden!

Uwagi pielęgnacyjne!
 Proszę wycierać ściereczką do kurzu lub lekko wilgotną ścierką. Nie stosować ZADNYCH środków rysujących powierzchnie.

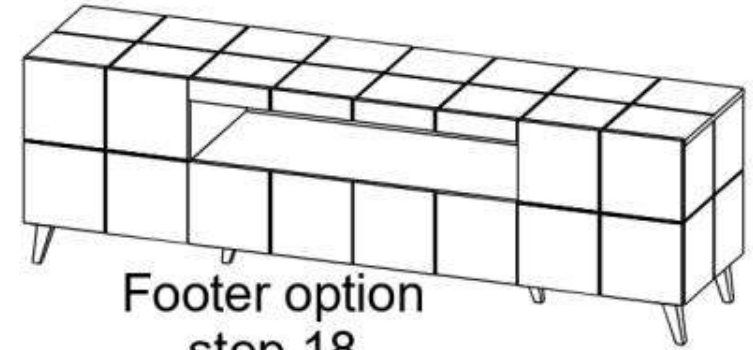

Footer option
step 18

BAG 1

K2 x33	T1 x23	M1 x23	S10 x10	P2 x8	K7 x1	K11 x14	W2 x8	S9 x12	Z1 x8
----------------------	----------------------	----------------------	-----------------------	---------------------	---------------------	-----------------------	---------------------	----------------------	---------------------

BAG 2

U1 x2L x2R	P10 x8	P2 x8
--------------------------	----------------------	---------------------

BAG 3

Z7 x4	S3 x8
---------------------	---------------------

BAG 4

X1 x12	S2 x24
----------------------	----------------------

BAG 5

ST1 x6	P2 x24
----------------------	----------------------

BAG 5

B5 x2

1

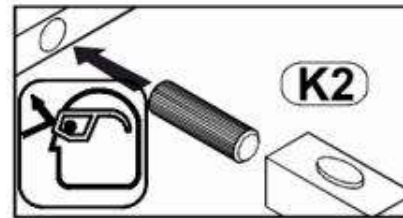
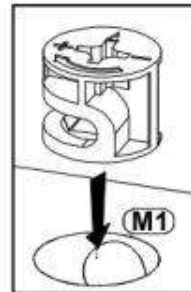
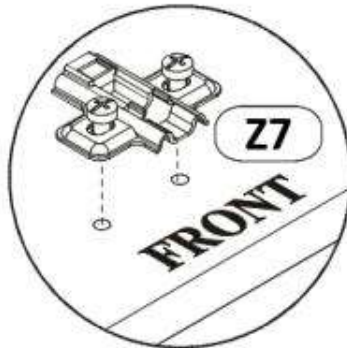
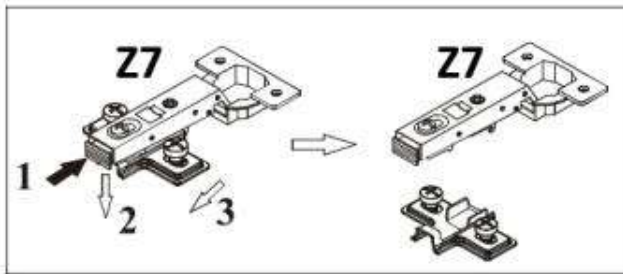
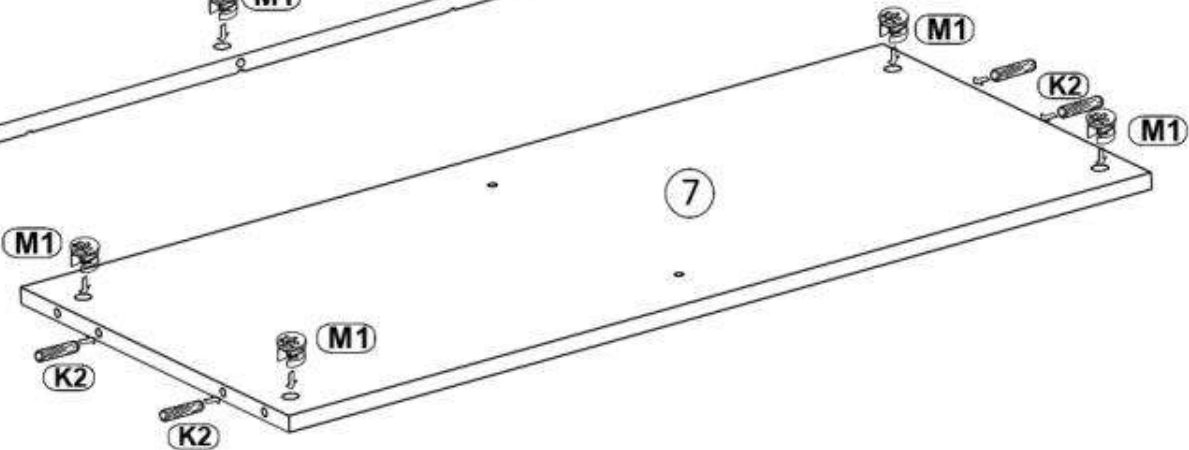
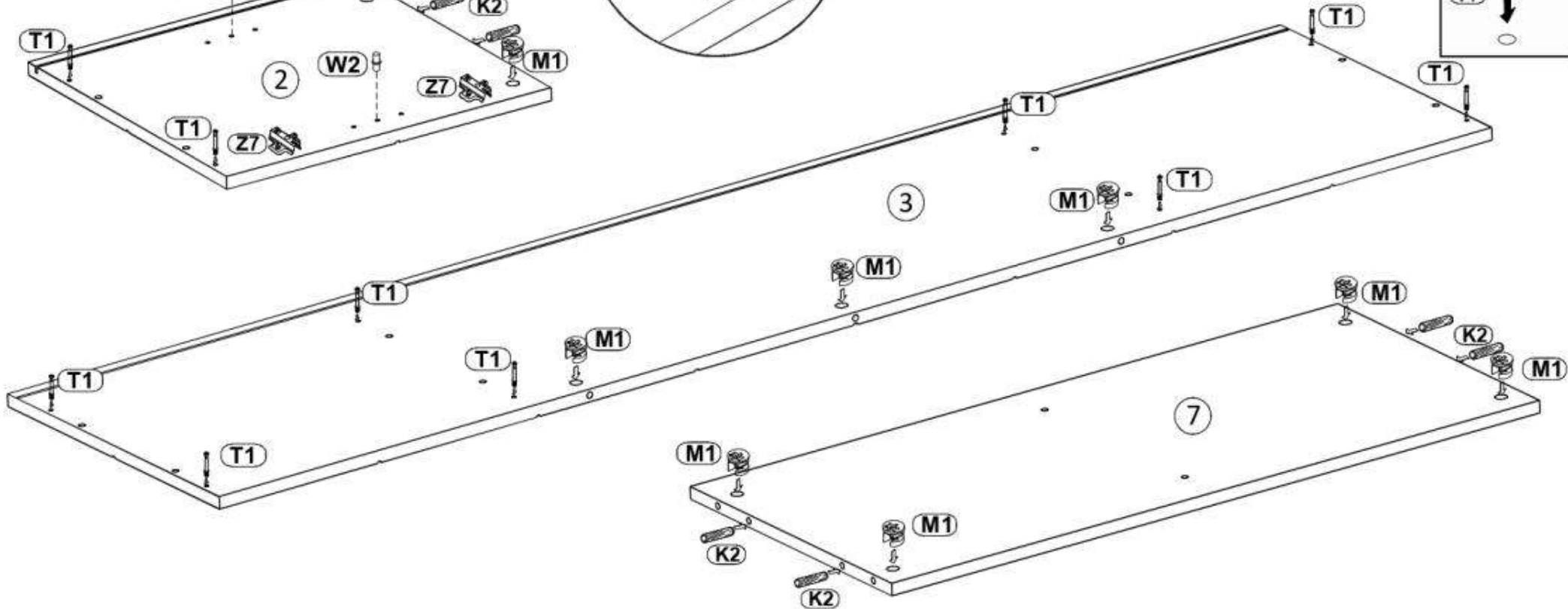
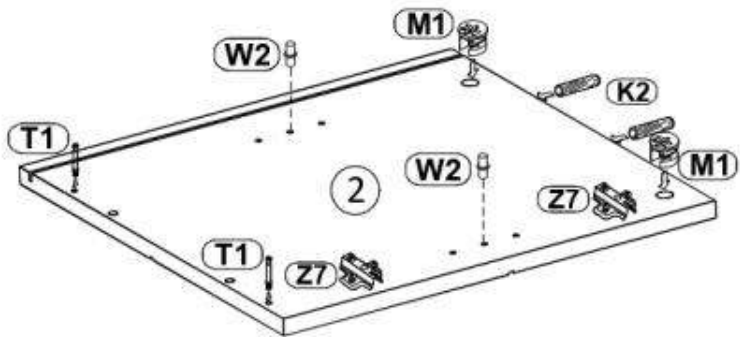
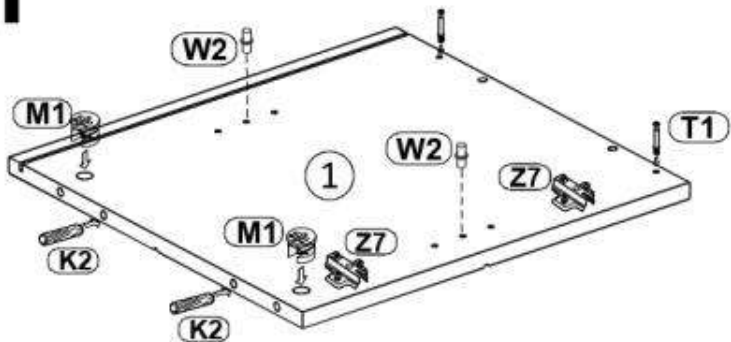

2

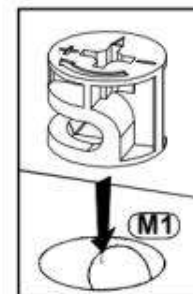
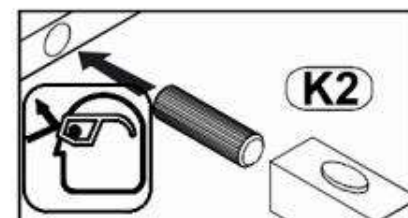
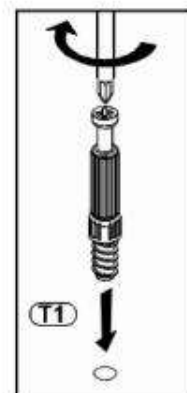
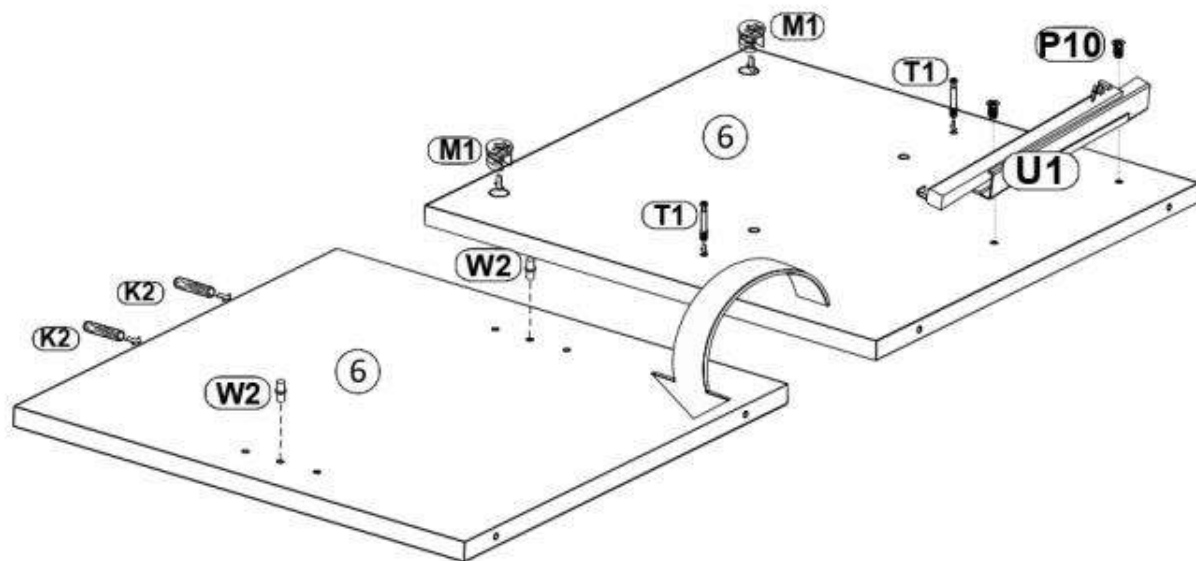
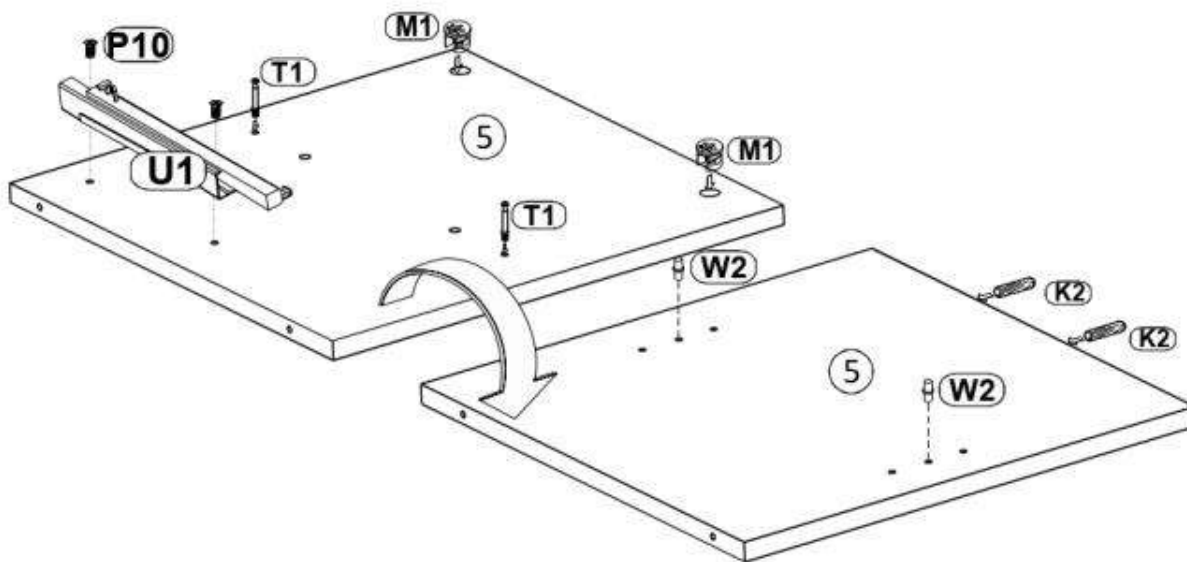
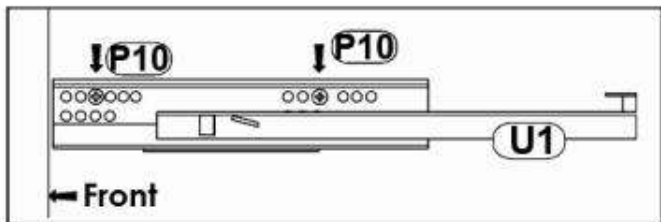

3

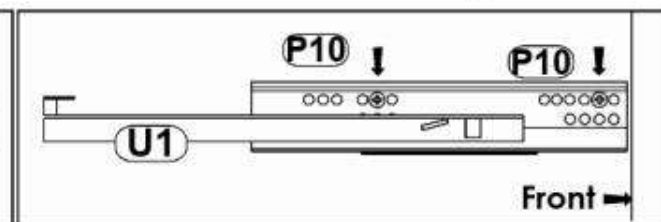
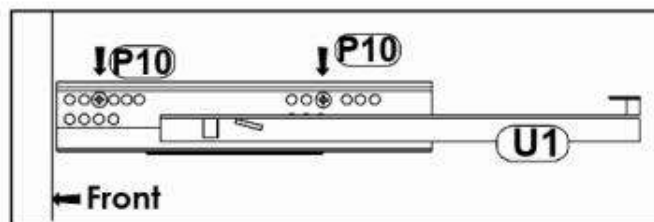
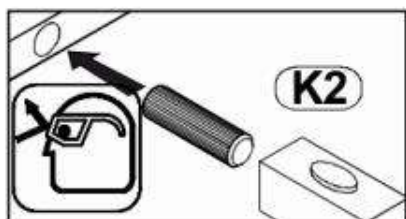
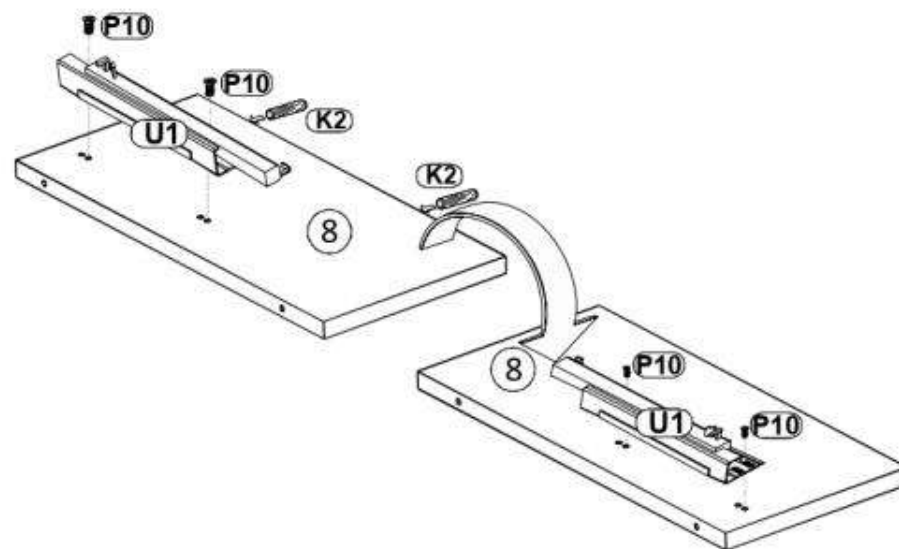
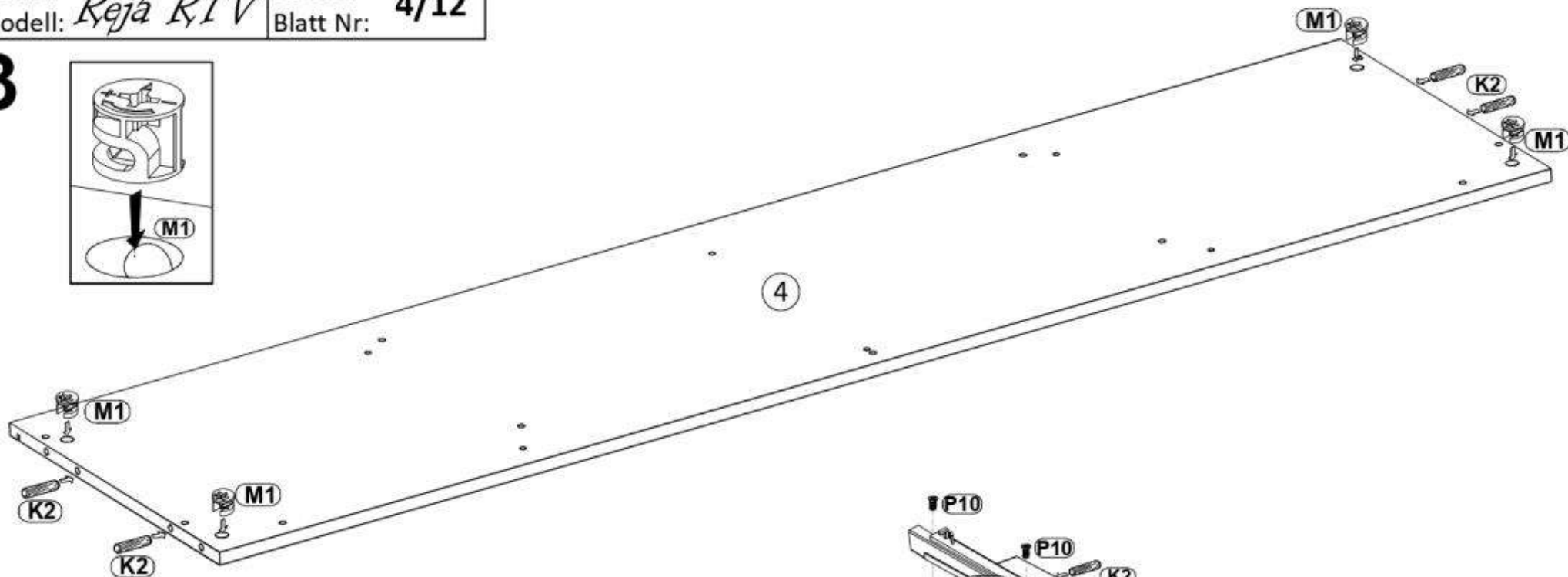
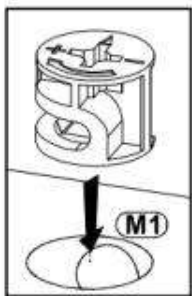

4

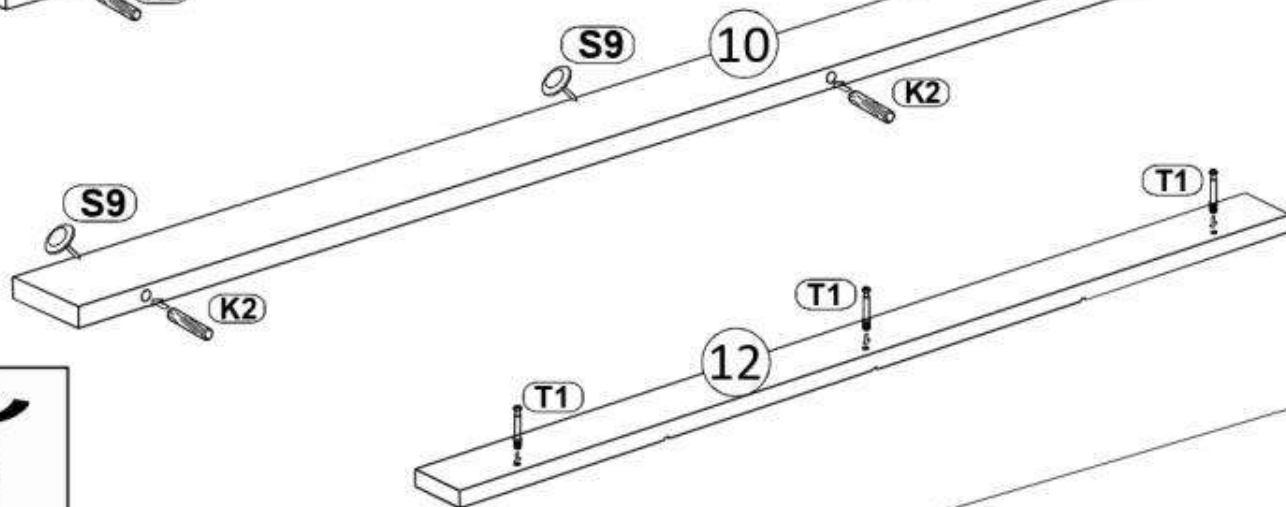
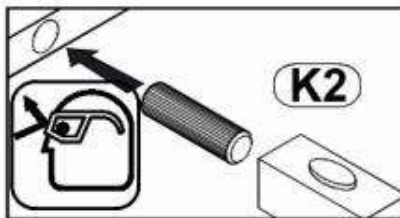
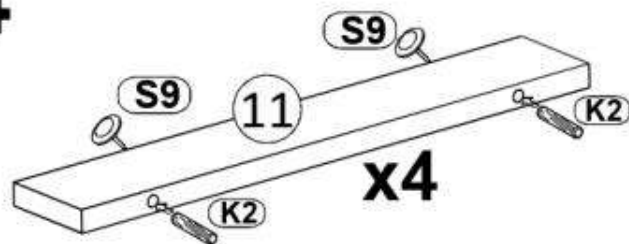

5

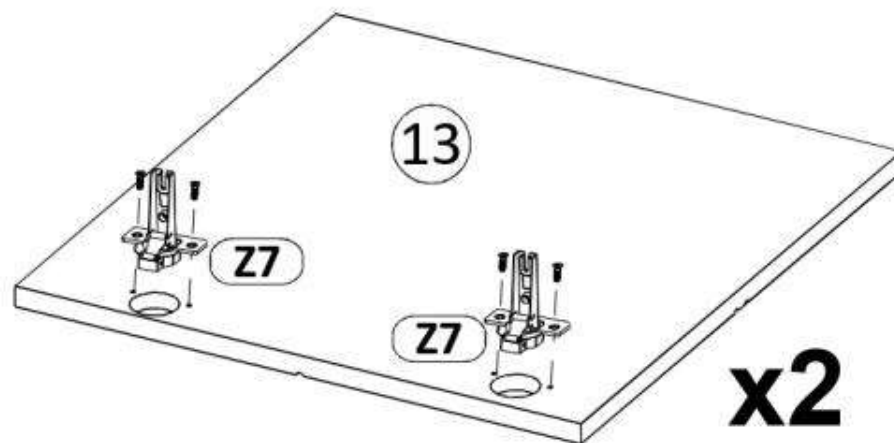
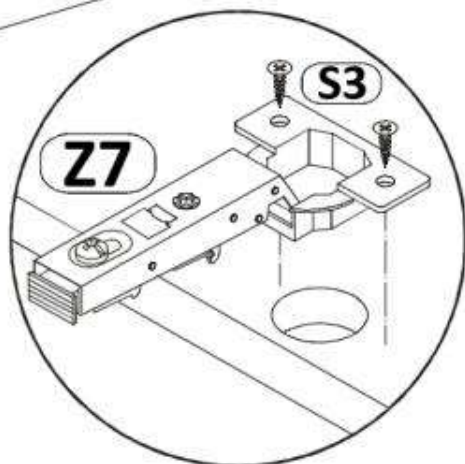

6

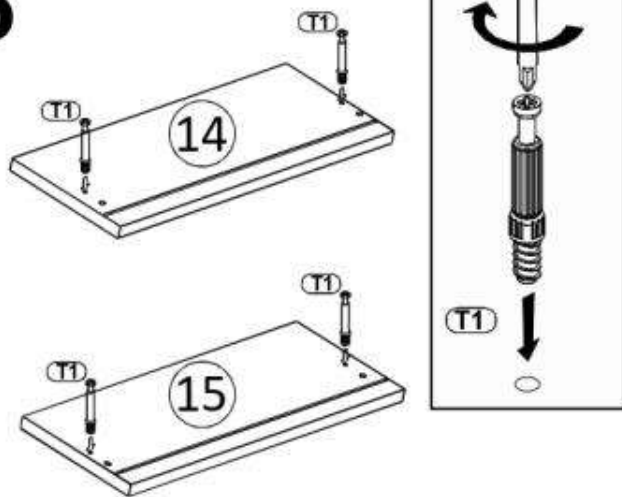

8

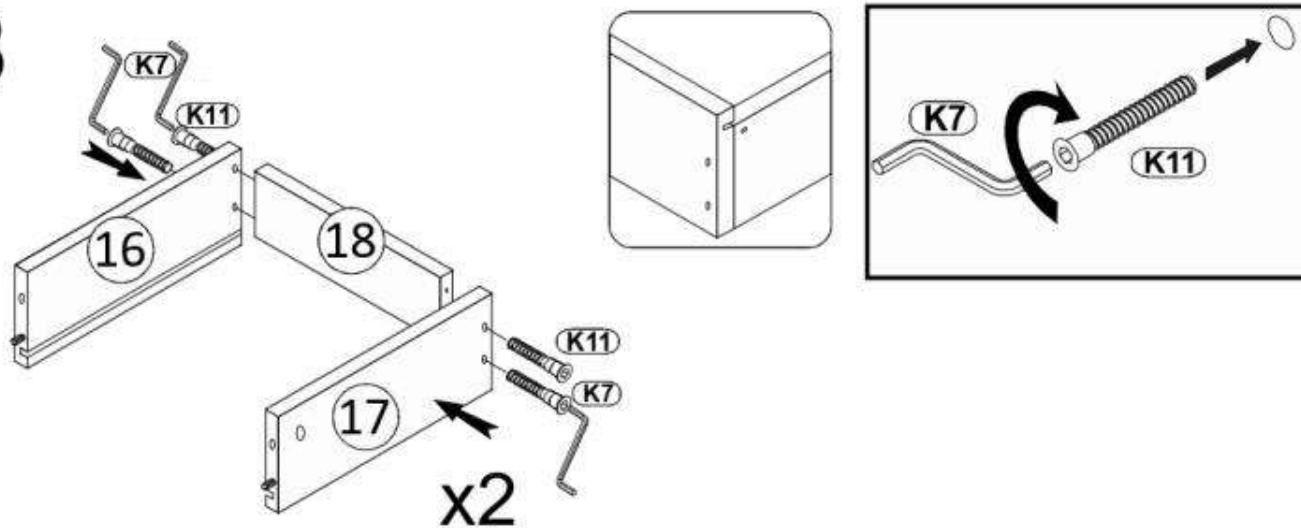

7

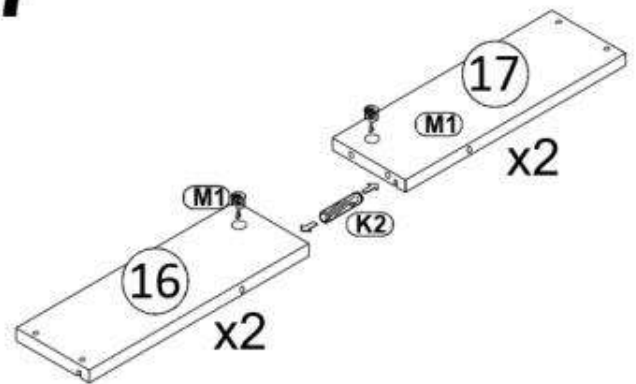

9

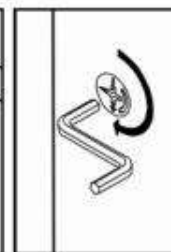
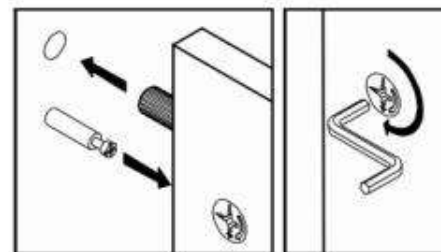
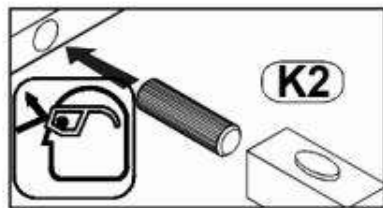
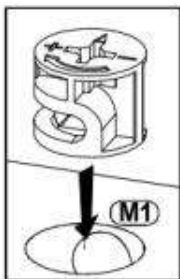
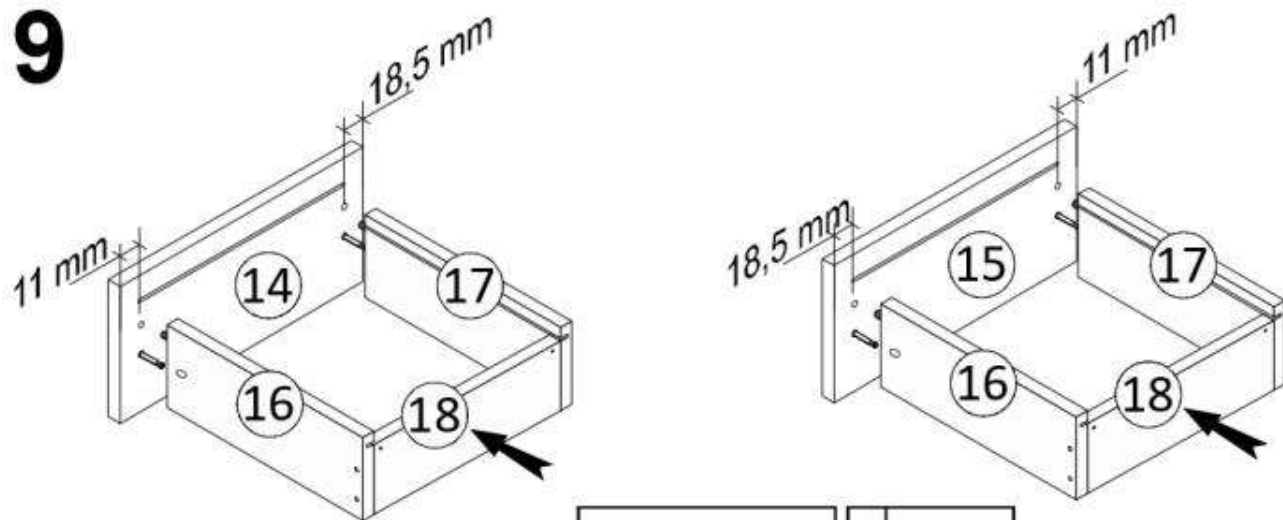

10

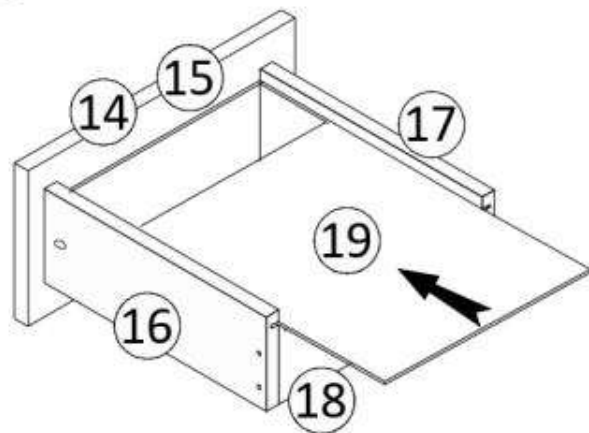

12

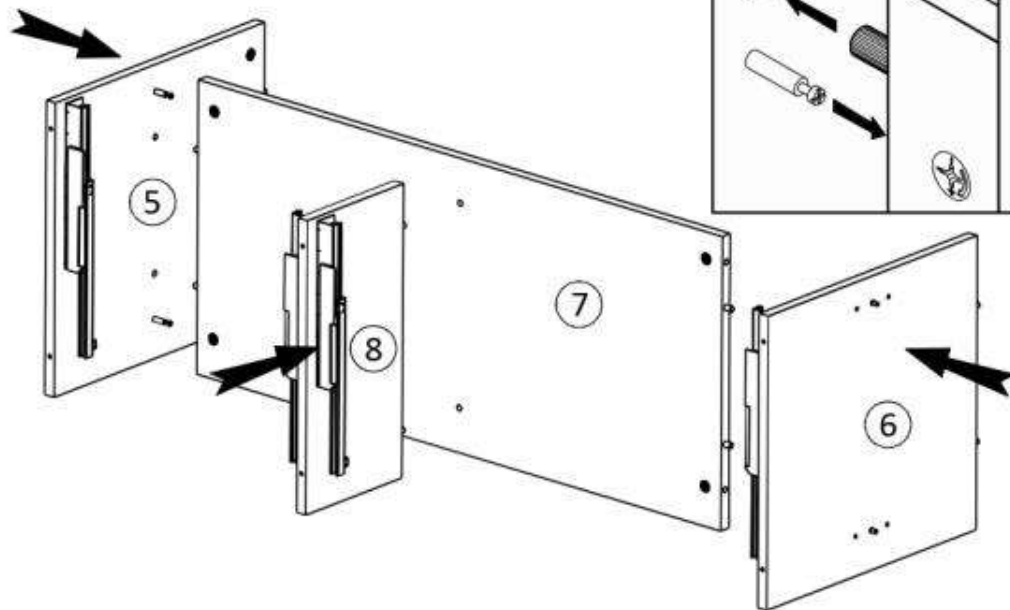

11

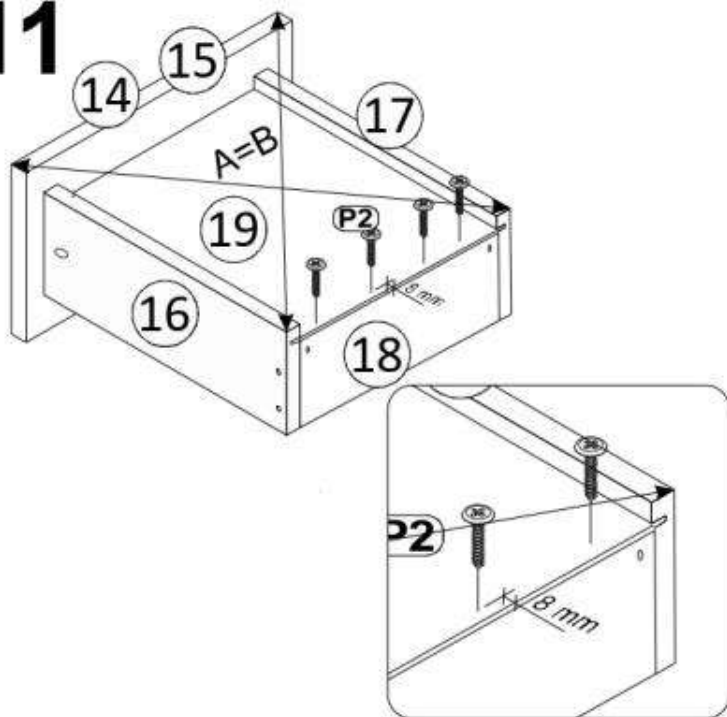

13

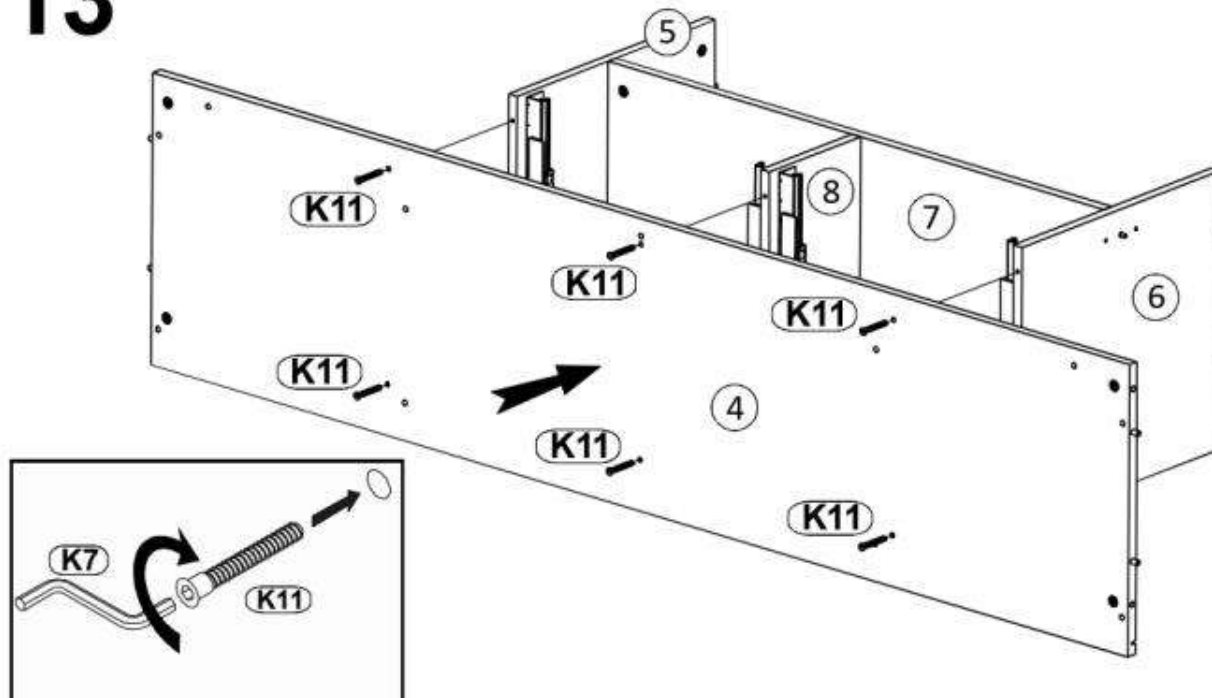

14

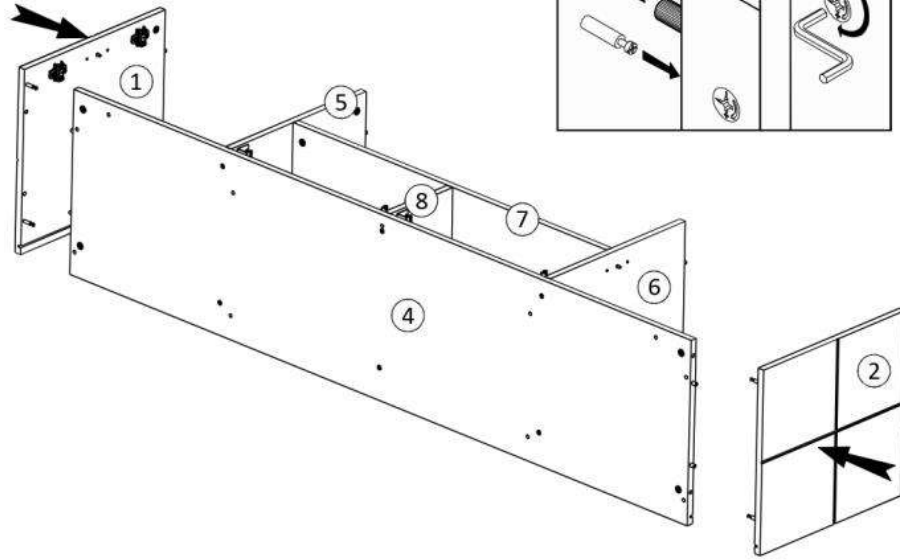

15

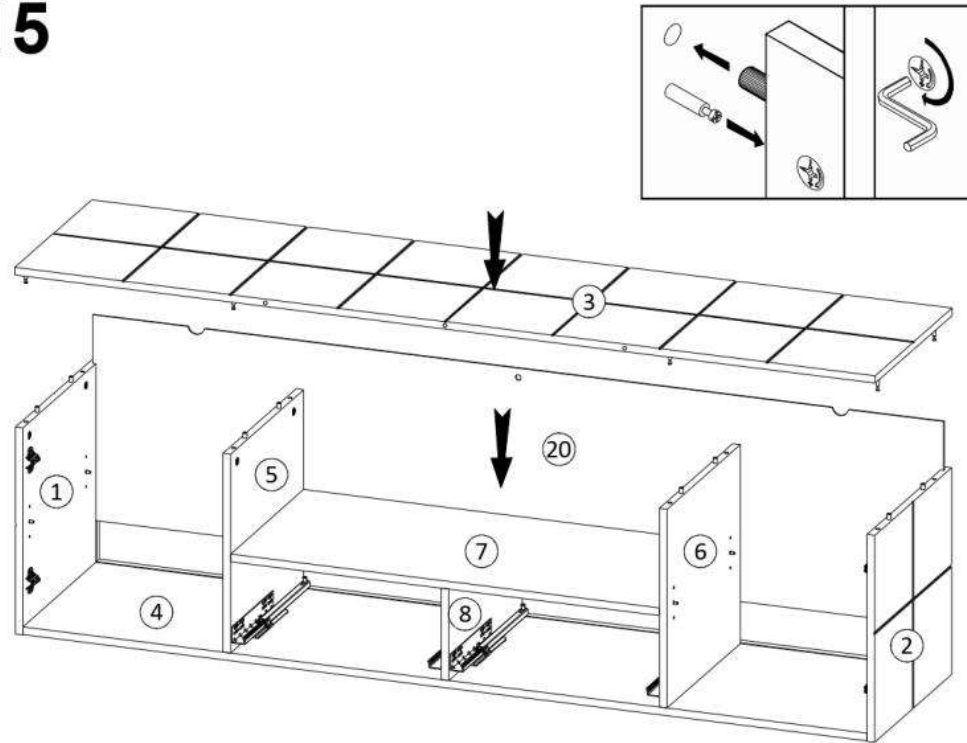

16

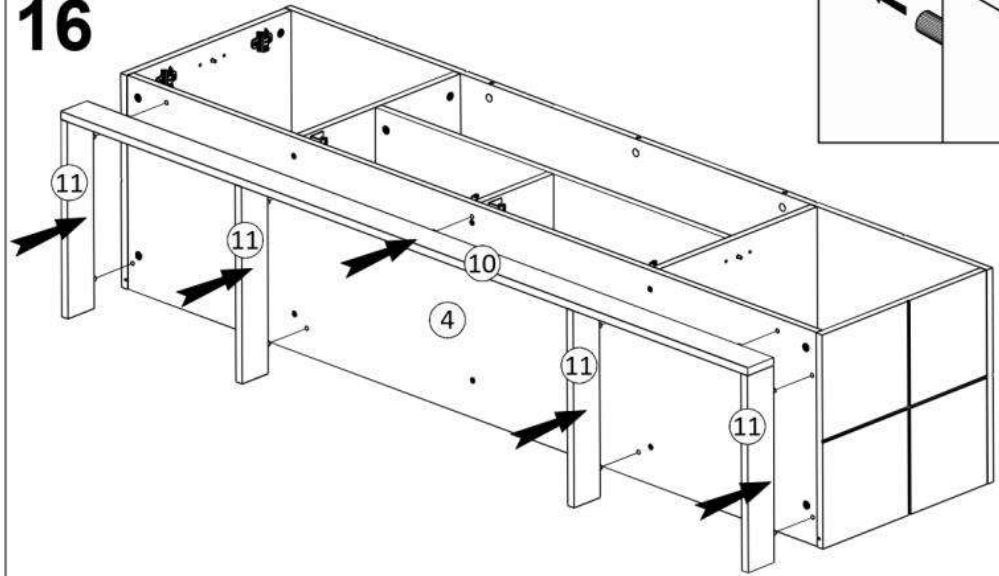

17

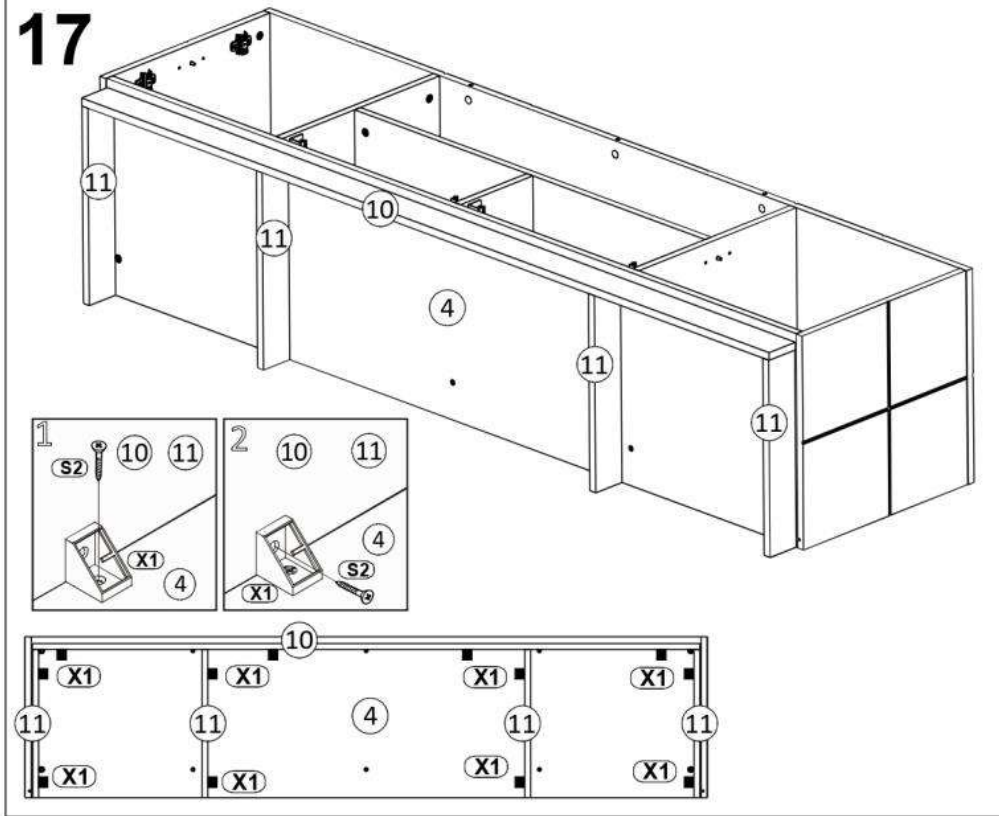

18

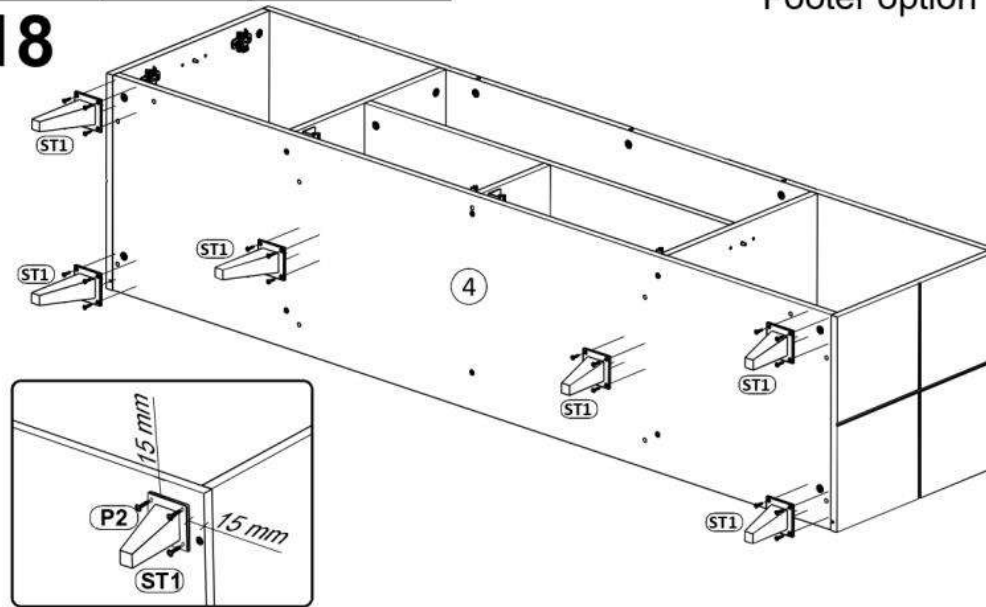

19

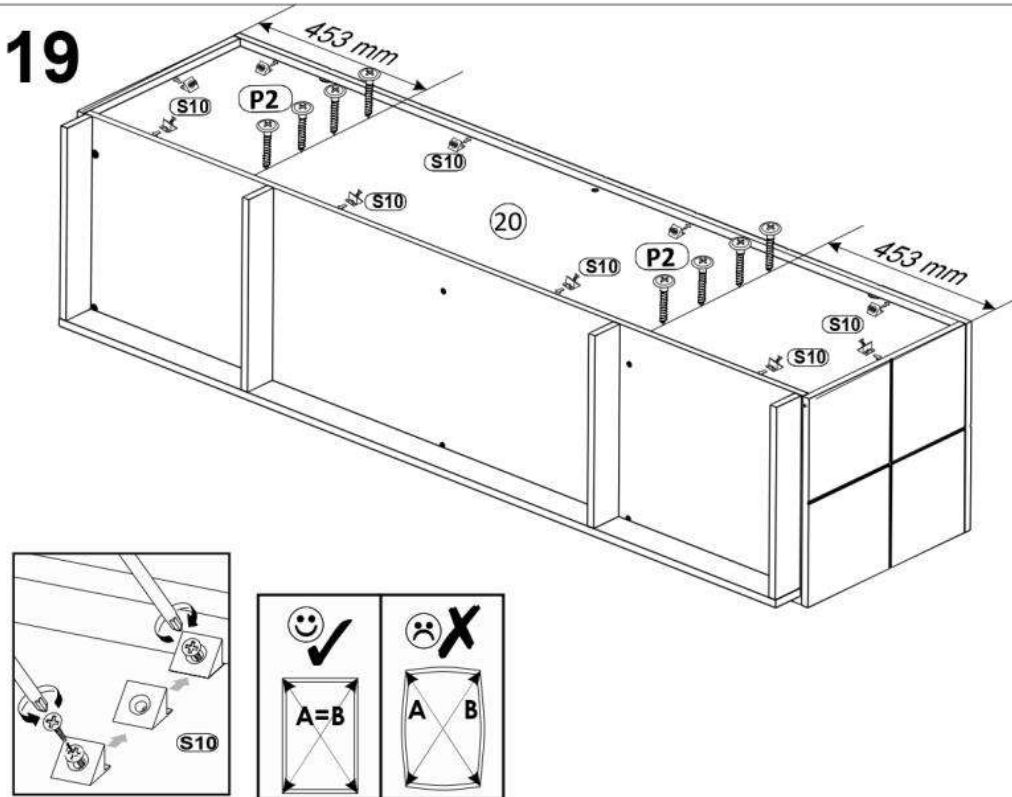

20

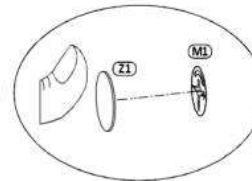
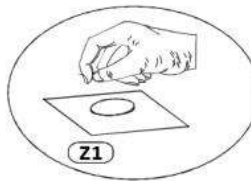
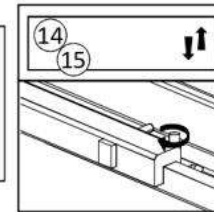
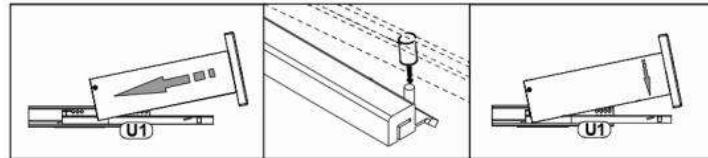
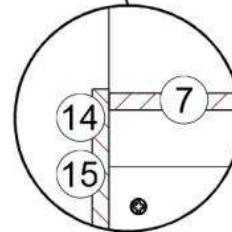
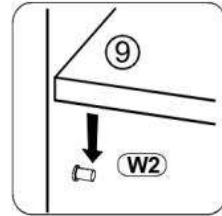
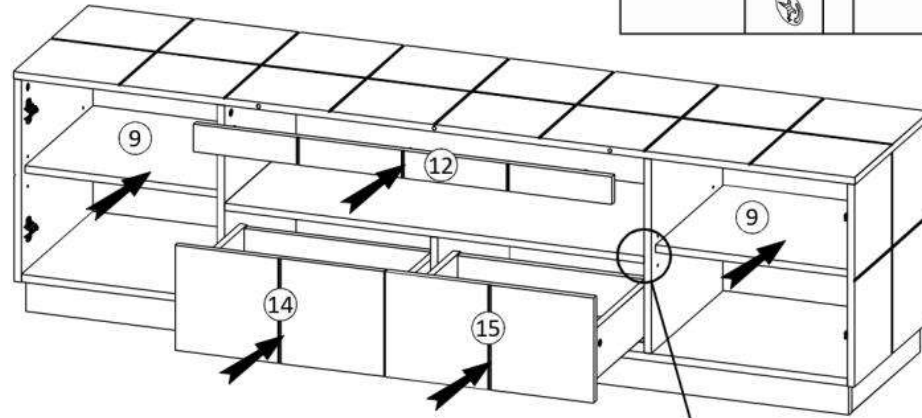
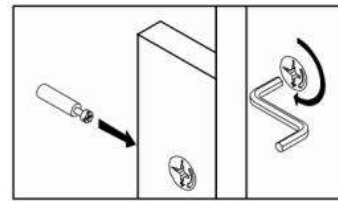

21

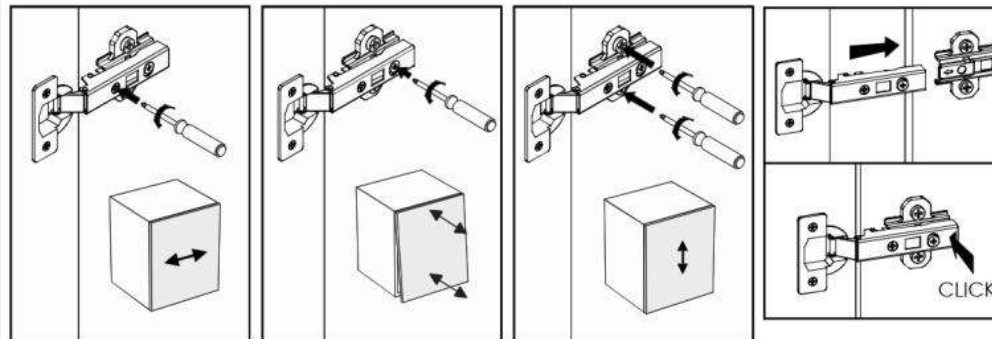
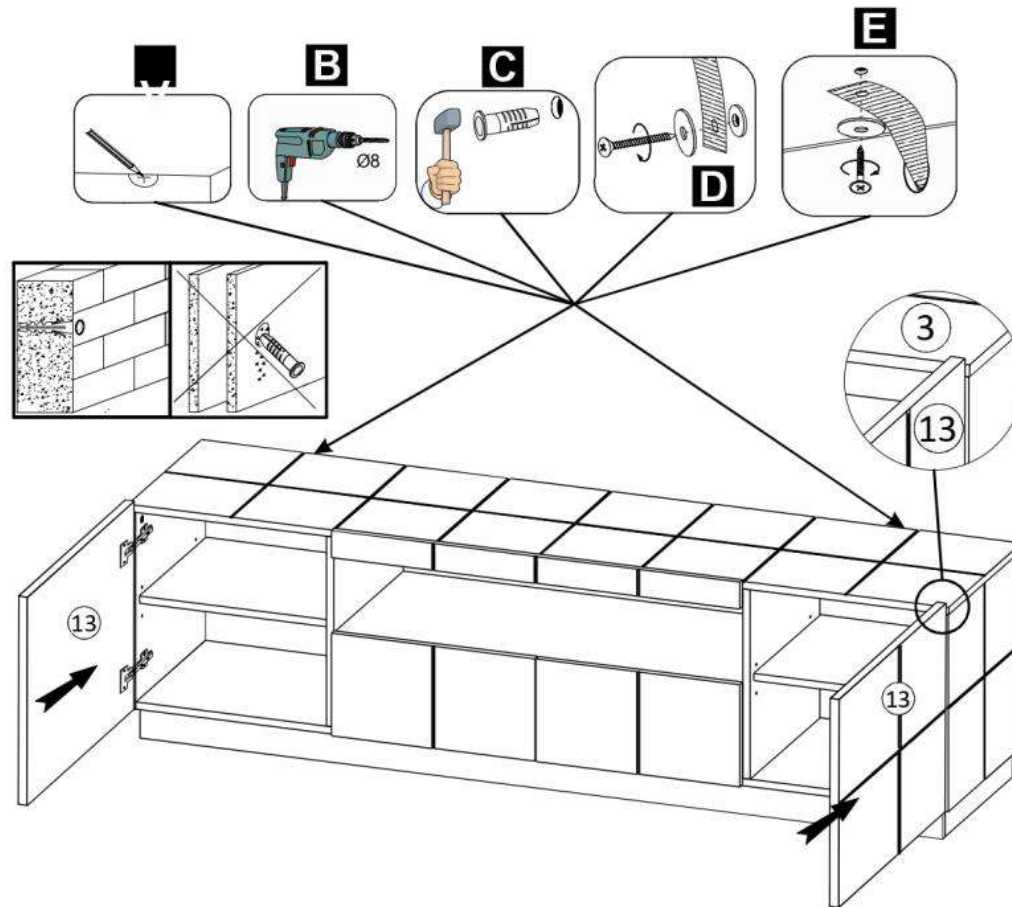

PL - UWAGA!

Nasze powierzchnie o wysokim połysku są fabrycznie ochronione specjalną folią ochronną. Prosimy pozostawić ją na meblach do momentu zmontowania i usunięcia kurzu. Po usunięciu folii ochronnej pozostawić folię połyskową przez 12 godzin w pomieszczeniu do stwardnienia.

EN - ATTENTION!

Our high gloss surfaces have a protective foil when delivered. Please leave this foil on the furniture until it is completely assembled and all dust has been removed. Expose the high gloss foil to the room air for 12 hours to allow it to harden after removing the protective foil.

DE - HINWEIS!

Unsere Hochglanzoberflächen sind bei der Auslieferung durch eine Schutzfolie geschützt. Belassen Sie diese auf dem Möbel, bis es vollständig montiert und von Staub befreit ist. Der Hochglanzfolie nach der Entfernung der Schutzfolie 12 Stunden Zeit zum Nachhärten an der Raum-Luft geben.

CZ - POZOR!

Naše povrchy s vysokým leskem jsou při dodání chráněny ochrannou fólií. Ponechejte ji na nábytku, dokud nebude kompletně smontovaný a nebude z něho odstraněný prach. Po odstranění folie dejte nábytku 12 hodin čas na vytvrzení v pokojové teplotě.

SK - POZOR!

Naše vysoko lesklé povrchy sú chránené špeciálnou ochrannou fóliou. Prosím, nechajte ju na nábytku, kým nábytok nezmontujete a neodstránite prach. Po odstránení ochrannej fólie nechajte lesklý film 12 hodín v miestnosti vytvrdnúť.

HU - FIGYELEM!

Az általunk gyártott bútorok magas fényű felületei speciális védőfóliával gyárilag védettek. Kérjük a védő fóliát ne távolítsák el a bútor összeszereléséig, és a por szerelést követő eltávolításáig. Avédőfólia eltávolítását követően tartsuk a bútort 12 órán át a fóliázott felületek megkeményedésére alkalmas környezetben.

HR - PAŽNJA!

Dijelovi namještaja u visokom sjaju imaju na sebi zaštitnu foliju prilikom isporuke. Molimo vas da tu foliju ostavite na namještaju dok nije u potpunosti montiran i dok nije odstranjena sva prašina u prostoru. Nakon uklanjanja zaštitne folije dijelove namještaja u visokom sjaju izložiti sobnom zraku 12 sati.

